

# MARK HEAT PUMP SPLIT-UNIT

0662680





# Read this document before installing the heater

## Warning

Incorrect installation, adjustment, alteration, repair or maintenance work may lead to material damage or injury. All work must be carried out by certified, qualified professionals. If the appliance is not positioned in accordance with the instructions, the warranty shall be rendered void. This appliance is not intended for use by children or persons with a physical, sensory or mental handicap, or who lack the required experience or expertise, unless they are supervised or have been instructed in the use of the appliance by somebody who is responsible for their safety. Children must be supervised to ensure that they do not play with the appliance.

### *Subject to change*

The manufacturer is committed to constantly improving its products and reserves the right to make changes in the specifications without prior notice. The technical details are considered correct but do not form the basis for a contract or warranty. All orders are accepted according to the standard terms of our general sales and delivery conditions (available upon request). The information in this document is subject to change without notice. The most recent version of this manual is always available at [www.markclimate.com/downloads](http://www.markclimate.com/downloads).

## 1.0 General

### 1.1 General warnings

To prevent personal injury, or property or unit damage, adhere to all precautionary measures and instructions outlined in this Manual. Before servicing a unit, refer to this Service Manual and its relevant sections.

Failure to adhere to all precautionary measures listed in this section may result in personal injury, damage to the unit or to property, or in extreme cases, death.





**WARNING:** indicates a potentially hazardous situation which if not avoided could result in serious personal injury, or death.



**CAUTION:** indicates a potentially hazardous situation which if not avoided could result in minor or moderate personal injury, or unit damage.

### 1.1.1 In case of Accidents or Emergency

 <b>WARNING</b>
<ul style="list-style-type: none"><li>• If a gas leak is suspected, immediately turn off the gas appliance and ventilate the area before turning the unit on.</li><li>• If strange sounds or smoke is detected coming from the unit, turn the breaker off and disconnect the power supply cable.</li><li>• If the unit comes into contact with liquid, contact an authorized Service Center.</li><li>• If liquid from the batteries makes contact with skin or clothing, immediately rinse or wash the area well with clean water.</li><li>• Do not insert hands or other objects into the air inlet or outlet while the unit is plugged in.</li><li>• Do not operate the unit with wet hands.</li><li>• Do not use a remote controller that has previously been exposed to battery damage or battery leakage.</li></ul>

 <b>CAUTION</b>
<ul style="list-style-type: none"><li>• Clean and ventilate the unit at regular intervals when operating it near a stove or near similar devices.</li><li>• Do not use the unit during severe weather conditions. If possible, disconnect the product from the power supply source before such occurrences.</li></ul>

### 1.1.2 Pre-Installation and Installation

 <b>WARNING</b>
<ul style="list-style-type: none"><li>• Use this unit only on a dedicated circuit.</li><li>• Damage to the installation area could cause the unit to fall, potentially resulting in personal injury, property damage, or product failure.</li><li>• Only qualified personnel should disassemble, install, remove, or repair the unit.</li><li>• Only a qualified electrician should perform electrical work. For more information, contact your dealer, reseller, or an authorized Service Center.</li></ul>

 <b>CAUTION</b>
<ul style="list-style-type: none"><li>• While unpacking, be careful of sharp edges around the unit as well as the edges of the fins on the condenser and evaporator.</li></ul>

 **WARNING**

- Do not use defective or underrated circuit breakers.
- Ensure the unit is properly grounded and that a dedicated circuit and breaker are installed.
- Do not modify or extend the power cable. Ensure the power cable is secure and not damaged during operation.
- Do not unplug the power supply plug during operation.
- Do not store or use flammable materials near the unit.
- Do not open the inlet grill of the unit during operation. Do not touch the electrostatic filter if the unit is equipped with one.
- Do not block the inlet or outlet of air flow to the unit.
- Do not use harsh detergents, solvents, or similar items to clean the unit. Use a soft cloth for cleaning.
- Do not touch the metal parts of the unit when removing the air filter as they are very sharp.
- Do not step on or place anything on the unit or outdoor units.
- Do not drink water drained from the unit.
- Avoid direct skin contact with water drained from the unit.
- Use a firm stool or step ladder according to manufacturer procedures when cleaning or maintaining the unit.

 **CAUTION**

- Do not install or operate the unit for an extended period of time in areas with high humidity or in an environment directly exposing it to sea wind or salt spray.
- Do not install the unit on a defective or damaged installation stand, or in an unsecure location.
- Ensure the unit is installed at a level position.
- Do not install the unit where noise or air discharge created by the outdoor unit will negatively impact the environment or nearby residences.
- Do not expose skin directly to the air discharged by the unit for prolonged periods of time.
- Ensure the unit operates in areas without splashes of water or other liquids.
- Ensure the drain hose is installed correctly to ensure proper water drainage.
- When lifting or transporting the unit, it is recommended that two or more people are used for this task.
- When the unit is not to be used for an extended time, disconnect the power supply or turn off the circuit breaker.

## 1.2 General instructions for installer, user and maintenance personnel

### Checks to the area

- Prior to beginning work on systems containing flammable refrigerants, safety checks are necessary to ensure that the risk of ignition is minimized.
- For repairs to the refrigerating system, the following precautions shall be complied with prior to conducting work on the system.

### Work procedure

- Work shall be undertaken under a controlled procedure so as to minimise the risk of a flammable gas or vapour being present while the work is being performed.

#### *Work area*

- All maintenance staff and others working in the local area shall be instructed on the nature of work being carried out.
- Work in confined spaces shall be avoided.
- The area around the work space shall be sectioned off. Ensure that the conditions within the area have been made safe by control of flammable material.

#### *Checking for presence of refrigerant*

- The area shall be checked with an appropriate refrigerant detector prior to and during work, to ensure the technician is aware of potentially flammable atmospheres.
- Ensure that the leak detection equipment being used is suitable for use with flammable refrigerants, i.e. no sparking, adequately sealed or intrinsically safe.

#### *Presence of fire extinguisher*

- If any hot work is to be conducted on the refrigeration equipment or any associated parts, appropriate fire extinguishing equipment shall be available to hand.
- Have a dry powder or CO<sub>2</sub> fire extinguisher adjacent to the charging area.

#### *No ignition sources*

- No person carrying out work in relation to a refrigeration system which involves exposing any pipe work that contains or has contained flammable refrigerant, shall use any sources of ignition in such a manner that it may lead to the risk of fire or explosion.
- All possible ignition sources, including cigarette smoking, should be kept sufficiently far away from the site of installation, repairing, removing and disposal, during which flammable refrigerant can possibly be released to the surrounding space.
- Prior to work taking place, the area around the equipment is to be surveyed to make sure that there are no flammable hazards or ignition risks.
- NO SMOKING signs shall be displayed.

#### *Ventilated area*

- Ensure that the area is in the open or that it is adequately ventilated before breaking into the system or conducting any hot work.
- A degree of ventilation shall continue during the period that the work is carried out.
- The ventilation should safely disperse any released refrigerant and preferably expel it externally into the atmosphere.

#### *Checks to the refrigeration equipment*

- Where electrical components are being changed, they shall be fit for the purpose and to the correct specification.

At all times the manufacturer's maintenance and service guidelines shall be followed.

If in doubt consult the manufacturer's technical department for assistance.

The following checks shall be applied to installations using flammable refrigerants:

- The charge size is in accordance with the room size within which the refrigerant containing parts are installed.
- The ventilation machinery and outlets are operating adequately and are not obstructed.
- If an indirect refrigerating circuit is being used, the secondary circuit shall be checked for the presence of refrigerant.
- Marking to the equipment continues to be visible and legible. Markings and signs that are illegible shall be corrected.
- Refrigeration pipe or components are installed in a position where they are unlikely to be exposed to any substance which may corrode refrigerant containing components, unless the components are constructed of materials which are inherently resistant to being corroded or are suitably protected against being so corroded.

### *Checks to electrical devices*

- Repair and maintenance to electrical components shall include initial safety checks and component inspection procedures.

If a fault exists that could compromise safety, then no electrical supply shall be connected to the circuit until it is satisfactorily dealt with.

If the fault cannot be corrected immediately but it is necessary to continue operation, an adequate temporary solution shall be used. This shall be reported to the owner of the equipment so all parties are advised.

Initial safety checks shall include:

- That capacitors are discharged: this shall be done in a safe manner to avoid possibility of sparking.
- That there no live electrical components and wiring are exposed while charging, recovering or purging the system.
- That there is continuity of earth bonding.

### *Repairs to sealed components*

- During repairs to sealed components, all electrical supplies shall be disconnected from the equipment being worked upon prior to any removal of sealed covers, etc. If it is absolutely necessary to have an electrical supply to equipment during servicing, then a permanently operating form of leak detection shall be located at the most critical point to warn of a potentially hazardous situation.
- Particular attention shall be paid to the following to ensure that by working on electrical components, the casing is not altered in such a way that the level of protection is affected. This shall include damage to cables, excessive number of connections, terminals not made to original specification, damage to seals, incorrect fitting of glands, etc.
  - Ensure that apparatus is mounted securely.
  - Ensure that seals or sealing materials have not degraded such that they no longer serve the purpose of preventing the ingress of flammable atmospheres. Replacement parts shall be in accordance with the manufacturer's specifications.

NOTE: The use of silicon sealant may inhibit the effectiveness of some types of leak detection equipment. Intrinsically safe components do not have to be isolated prior to working on them.

### *Repair to intrinsically safe components*

- Do not apply any permanent inductive or capacitance loads to the circuit without ensuring that this will not exceed the permissible voltage and current permitted for the equipment in use. Intrinsically safe components are the only types that can be worked on while live in the presence of a flammable atmosphere. The test apparatus shall be at the correct rating.
- Replace components only with parts specified by the manufacturer. Other parts may result in the ignition of refrigerant in the atmosphere from a leak.

### *Repair to intrinsically safe components*

- Check that cabling will not be subject to wear, corrosion, excessive pressure, vibration, sharp edges or any other adverse environmental effects.
- The check shall also take into account the effects of aging or continual vibration from sources such as compressors or fans.

### *Detection of flammable refrigerants*

- Under no circumstances shall potential sources of ignition be used in the searching for or detection of refrigerant leaks.
- A halide torch (or any other detector using a naked flame) shall not be used.

### *Leak detection methods*

- The following leak detection methods are deemed acceptable for systems containing flammable refrigerants.  
Electronic leak detectors shall be used to detect flammable refrigerants, but the sensitivity may not

be adequate, or may need recalibration. (Detection equipment shall be calibrated in a refrigerant-free area.) Ensure that the detector itself is not a potential source of ignition and is suitable for the refrigerant used.

Leak detection equipment shall be set at a percentage of the "LFL" of the refrigerant and shall be calibrated to the refrigerant employed and the appropriate percentage of gas (25 % maximum) is confirmed.

Leak detection fluids are suitable for use with most refrigerants but the use of detergents containing chlorine shall be avoided as the chlorine may react with the refrigerant and corrode the copper pipework.

- If a leak is suspected, all naked flames shall be removed or extinguished.
- If a leakage of refrigerant is found which requires brazing, all of the refrigerant shall be recovered from the system, or isolated (by means of shut off valves) in a part of the system remote from the leak. Oxygen free nitrogen (OFN) shall then be purged through the system both before and during the brazing process.

#### *Removal and evacuation*

- When breaking into the refrigerant circuit to make repairs or for any other purpose, conventional procedures shall be used.

- However, it is important that best practice is followed since flammability is a consideration.

The following procedure shall be adhered to:

- Remove refrigerant.
- Purge the circuit with inert gas.
- Evacuate.
- Purge again with inert gas.
- Open the circuit by cutting or brazing.

- The refrigerant charge shall be recovered into the correct recovery cylinders.

- The system shall be flushed with OFN to render the unit safe. This process may need to be repeated several times. Compressed air or oxygen shall not be used for this task.

Flushing shall be achieved by breaking the vacuum in the system with OFN and continuing to fill until the working pressure is achieved, then venting to atmosphere, and finally pulling down to a vacuum. This process shall be repeated until no refrigerant is within the system.

When the final OFN charge is used, the system shall be vented down to atmospheric pressure to enable work to take place. This operation is absolutely vital if brazing operations on the pipework are to take place.

Ensure that the outlet for the vacuum pump is not close to any ignition sources and there is ventilation available.

#### *Charging procedures*

- In addition to conventional charging procedures, the following requirements shall be followed:

- Ensure that contamination of different refrigerants does not occur when using charging equipment.
- Hoses or lines shall be as short as possible to minimize the amount of refrigerant contained in them.
- Cylinders shall be kept upright.
- Ensure that the refrigeration system is earthed prior to charging the system with refrigerant.
- Label the system when charging is complete (if not already done).
- Extreme care shall be taken not to overfill the refrigeration system.
- Prior to recharging the system it shall be pressure tested with OFN.
- The system shall be leak tested on completion of charging but prior to commissioning.
- A follow up leak test shall be carried out prior to leaving the site.

#### *Leak detection methods*

Before carrying out this procedure, it is essential that the technician is completely familiar with the



equipment and all its detail.

It is recommended good practice that all refrigerants are recovered safely.

Prior to the task being carried out, an oil and refrigerant sample shall be taken.

Prior to re-use of reclaimed refrigerant, analysis is required.

It is essential that electrical power is available before the task is commenced.

- Become familiar with the equipment and its operation.
- Isolate system electrically.
- Before attempting the procedure ensure that:
  - Mechanical handling equipment is available, if required, for handling refrigerant cylinders.
  - All personal protective equipment is available and being used correctly.
  - The recovery process is supervised at all times by a competent person.
  - Recovery equipment and cylinders conform to the appropriate standards.
- Pump down refrigerant in the system, if possible.
- If a vacuum is not possible, make a manifold so that refrigerant can be removed from various parts of the system.
- Make sure that cylinder is situated on the scales before recovery takes place.
- Start the recovery machine and operate in accordance with manufacturer's instructions.
- Do not overfill cylinders. (No more than 80% volume liquid charge).
- Do not exceed the maximum working pressure of the cylinder, even temporarily.
- When the cylinders have been filled correctly and the process is completed, make sure that the cylinders and the equipment are removed from site promptly and all isolation valves on the equipment are closed off.
- Recovered refrigerant shall not be charged into another refrigeration system unless it has been cleaned and checked.

#### *Labelling*

- Equipment shall be labelled stating that it has been de-commissioned and emptied of refrigerant. The label shall be dated and signed.
- Ensure that there are labels on the equipment stating the equipment contains flammable refrigerant.









#### *Recovery*

- When removing refrigerant from a system, either for servicing or decommissioning, it is recommended good practice that all refrigerants are removed safely.
- When transferring refrigerant into cylinders, ensure that only appropriate refrigerant recovery cylinders are employed.  
Ensure that the correct numbers of cylinders for holding the total system refrigerant charge are available.  
All cylinders to be used are designated for the recovered refrigerant and labelled for that refrigerant (i.e. special cylinders for the recovery of refrigerant).  
Cylinders shall be complete with pressure relief valve and associated shut-off valves in good working order.
- Empty recovery cylinders are evacuated and, if possible, cooled before recovery occurs.
- The recovery equipment shall be in good working order with a set of instructions concerning the equipment that is at hand and shall be suitable for the recovery of flammable refrigerants.
- In addition, a set of calibrated weighting scales shall be available and in good working order.
- Hoses shall be complete with leak-free disconnect couplings and in good condition.
- Before using the recovery machine, check that it is in satisfactory working order, it has been properly maintained and that any associated electrical components are sealed to prevent ignition in the event of a refrigerant release. Consult manufacturer if in doubt.
- The recovered refrigerant shall be returned to the refrigerant supplier in the correct recovery cylinder, and the relevant "Waste Transfer Note" was arranged.
- Do not mix refrigerants in recovery units and especially not in cylinders.

- If compressors or compressor oils are to be removed, ensure that they have been evacuated to an acceptable level to make certain that flammable refrigerant does not remain within the lubricant. The evacuation process shall be carried out prior to returning the compressor to the suppliers. Only electric heating to the compressor body shall be employed to accelerate this process.
- When oil is drained from a system, it shall be carried out safely.

## 2.0 Specifications

### 2.1 Product overview

			
<b>Sleep mode</b>	<b>Comfort care</b>	<b>Silence mode</b>	<b>Refrigerant leak detection</b>
It allows reducing energy consumption at night. In cooling mode, the system increases the ambient temperature within 2 hours, by 2° C (in heating mode the system decreases the temperature by 2° C). At the end of the 2 hours the fan of the indoor unit works at low speed. The system keeps the room temperature constant for the next 5 hours.	MARK HEAT PUMP SPLIT-UNITS are equipped with a device that automatically regulates the temperature and moisture in the room.	This function allows the operating speed of the outdoor unit's compressor and indoor unit's motor fan to be reduced to their minimum so as to reduce noise and energy consumption to a minimum.	Active only in cooling mode, it allows to identify compressor malfunctions following the refrigerant leak.
			
<b>Cold currents prevention</b>	<b>Anti-freeze function 8°C</b>	<b>24H timer</b>	<b>24H timer</b>
Through this function in heating mode, it is possible to avoid the introduction of cold air into the room following the defrost cycles.	In the case of prolonged absence, a minimum temperature level can be guaranteed inside the rooms. When the room's temperature decreases than 8°, by the activation of the anti-freeze function the system starts until this temperature is reached.	This function allows users to select delayed air conditioner on and/or off within 24 hours, either via remote (standard) or via Wi-Fi (optional).	MARK HEAT PUMP SPLIT-UNIT is equipped with high-density filters that ensure the removal of pollen and dust up to 80% and prolong the effect without impurities, to always have clean room air.

## 2.2 Technical data

	Indoor unit model	HKEU 353	HKEU 533	
	Outdoor unit model	HCNMX 353	HCNI 533	
Type		DC-Inverted heat pump		
Control		Infra-red		
Rated capacity (T=+35 °C)	Cooling	kW	3.52 (1.11~4.16)	5.28 (1.82~6.13)
Rated absorbed power (T=+35 °C)		KW	1.21 (0.13~1.58)	1.54 (0.14~2.36)
Rated energie efficiency coefficient		EER	2.91	3.43
Seasonal energy efficiency class		626/2011	A++	A++
Seasonal energy efficiency index		SEER	6.1	7.1
Annual energy consumption		kWh/a	221	256
Theoretical load (Pdesignc)		kW	3.60	5.20
Operating limits (outside temperature)		°C	-15~50	
Rated capacity (T=+7 °C)	Heating	kW	3.81 (1.08~4.22)	5.57 (1.38~6.74)
Rated absorbed power (T=+7 °C)		kW	1.09 (0.10~1.68)	1.48 (0.20~2.41)
Rated energy performance coefficient		COP	3.50	3.76
Energy efficiency class (average season)		626/2011	A+	A+
Seasonal energy efficiency class index (average season)		SCOP	4.0	4.0
Annual energy consumption		kWh/a	945	1435
Theoretical load (Pdesignc) @ -10 °C		kW	2.70	4.10
Operating limits (outside temperature)		°C	-15~30	
<b>Electrical data</b>				
Power supply	Outdoor unit	Ph-V-Hz	1Ph-220/240V-50Hz	
Power cable		Type	3 x 2.5 mm <sup>2</sup>	3 x 4 mm <sup>2</sup>
Indoor and outdoor unit communication cable		Type	5 x 1.5 mm <sup>2</sup>	5 x 1.5 mm <sup>2</sup>
<b>Refrigerant circuit</b>				
Refrigerant (GWP)			R32(675)	R32(675)
Diameter of refrigerant piping on liquid/gas		mm (inches)	Ø6.35(1/4") - Ø9.52(3/8")	Ø6.35(1/4") - Ø12.74(1/2")
Max splitting length		m	25	30
Max height difference I.U./O.U.		m	10	20
Split length without additional charge		m	5	5
Additional load		g/m	12	12
<b>Indoor unit specifications</b>				
Net weight		Kg	7.6	10
Sound pressure level (I.U.)	Hi/Me/Lo	dB(A)	40.5/34.5/25	44/37/25
Sound power level (I.U.)	Hi	dB(A)	55	55
Treated air volume	Hi/Me/Lo	m <sup>3</sup> /h	540/430/314	840/680/540
Motor power (Output)		W	40	36
<b>Outdoor unit specifications</b>				
Net weight		Kg	23.2	34
Sound pressure level (O.U.)		dB(A)	56	56
Sound power level (O.U.)		dB(A)	63	61
Treated air (Max)		m <sup>3</sup> /h	1800	2500
Motor power (Output)		W	63	63

## 2.3 Pipe length and drop height

The length and elevation of connection pipe are shown in the table below.

If the pipe length exceeds max. pipe length corresponding to refrigerant precharge, additional refrigerant (R32) should be charged to ensure nominal cooling/heating capacity and prevent any damages to the air conditioner.

Model	Standard Length	Max Pipe Length	Max Elevation	Additional R32 Charge
353	5m	25m	10m	12g/m
533		30m	20m	

If oil flows back into the outdoor unit's compressor, this might cause liquid compression or deterioration of oil return. Oil traps in the rising gas pipe can prevent this.

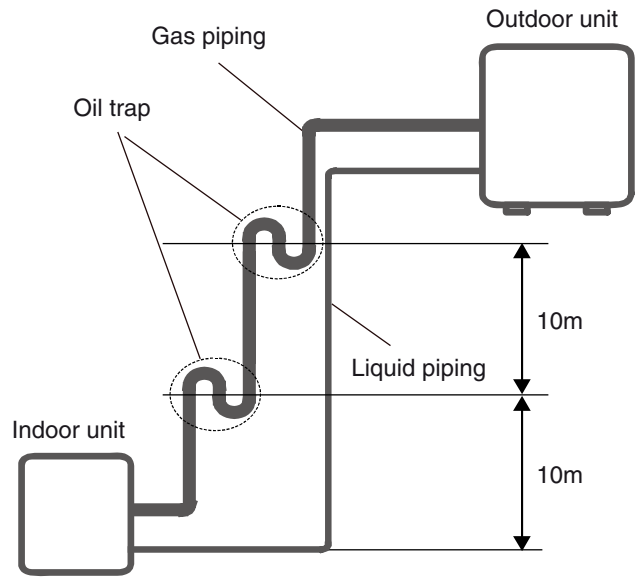
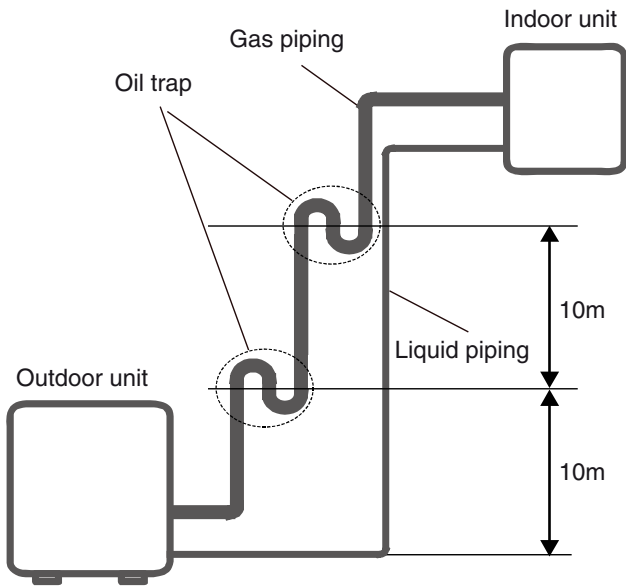

1. Indoor unit is installed higher than outdoor unit    2. Outdoor unit is installed higher than indoor unit.

If indoor unit is installed higher than outdoor unit, oil trap should be set every 10m of vertical distance. If the outdoor unit is installed higher than the indoor unit, proper oil should return to the compressor along with the suction of refrigerant to keep lubrication of compressor.

If the suction flow velocity drops below 7.62m/s, oil won't return to the compressor. An oil trap should be installed every 6m of vertical distance.

# 3.0 Electrical wiring diagrams

## 3.1 Indoor Units' Wiring Diagram HKEU 353 / 533

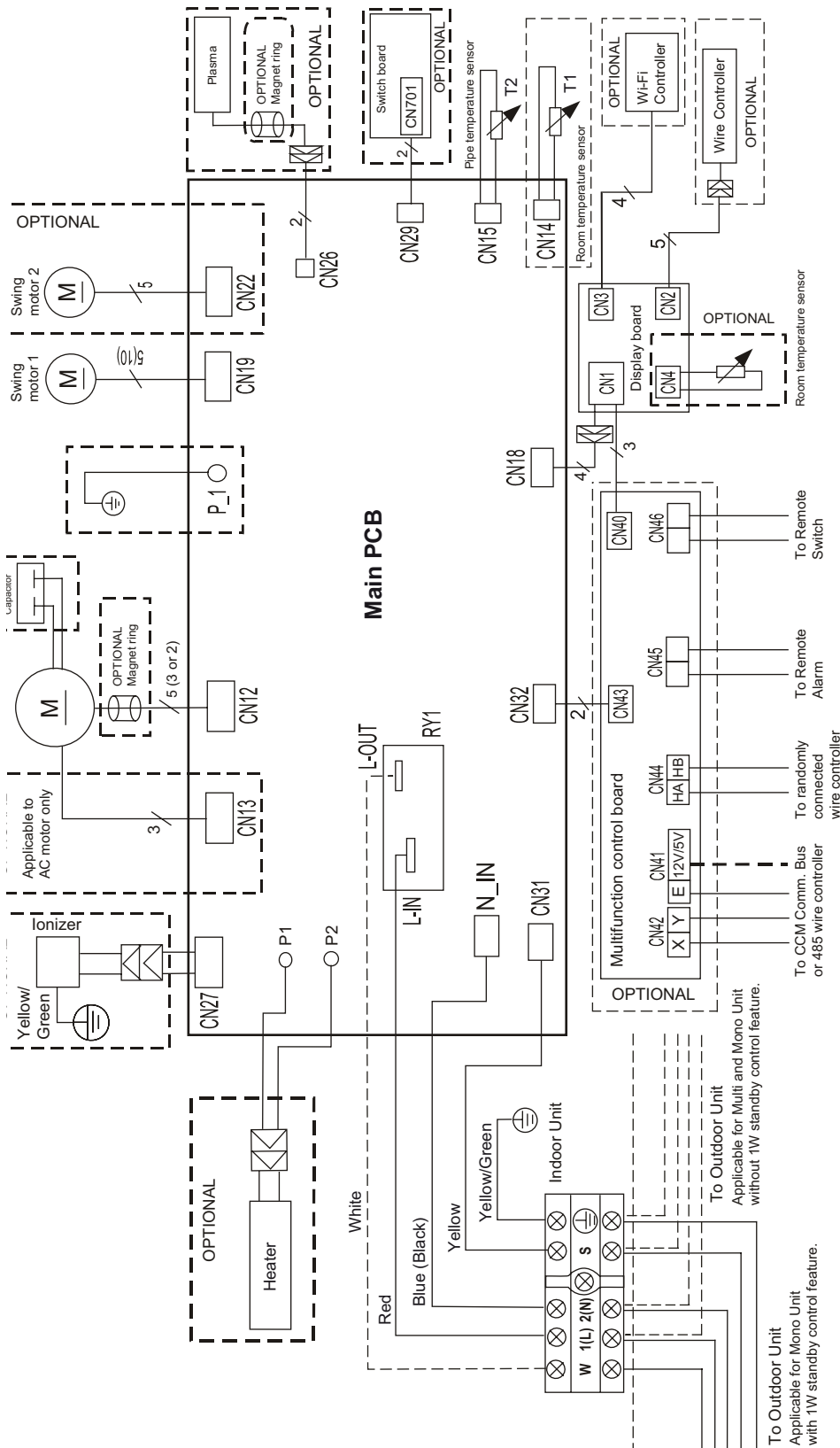

For setting Net address (CCM Comm. Bus)

ENC3 + F1 (Multifunction control board)	ON	0 ~ F	0 ~ F	0 ~ F	0 ~ F
Code	ON	0 ~ F	0 ~ F	0 ~ F	0 ~ F
Net address	ON	0 ~ 15	16 ~ 31	32 ~ 47	48 ~ 63

Encoder rotation

Note: - - - - This symbol indicates the element is optional, the actual shape will prevail.

### 3.2 Outdoor Units' Wiring Diagram HCNMX 353 / HCNI 533

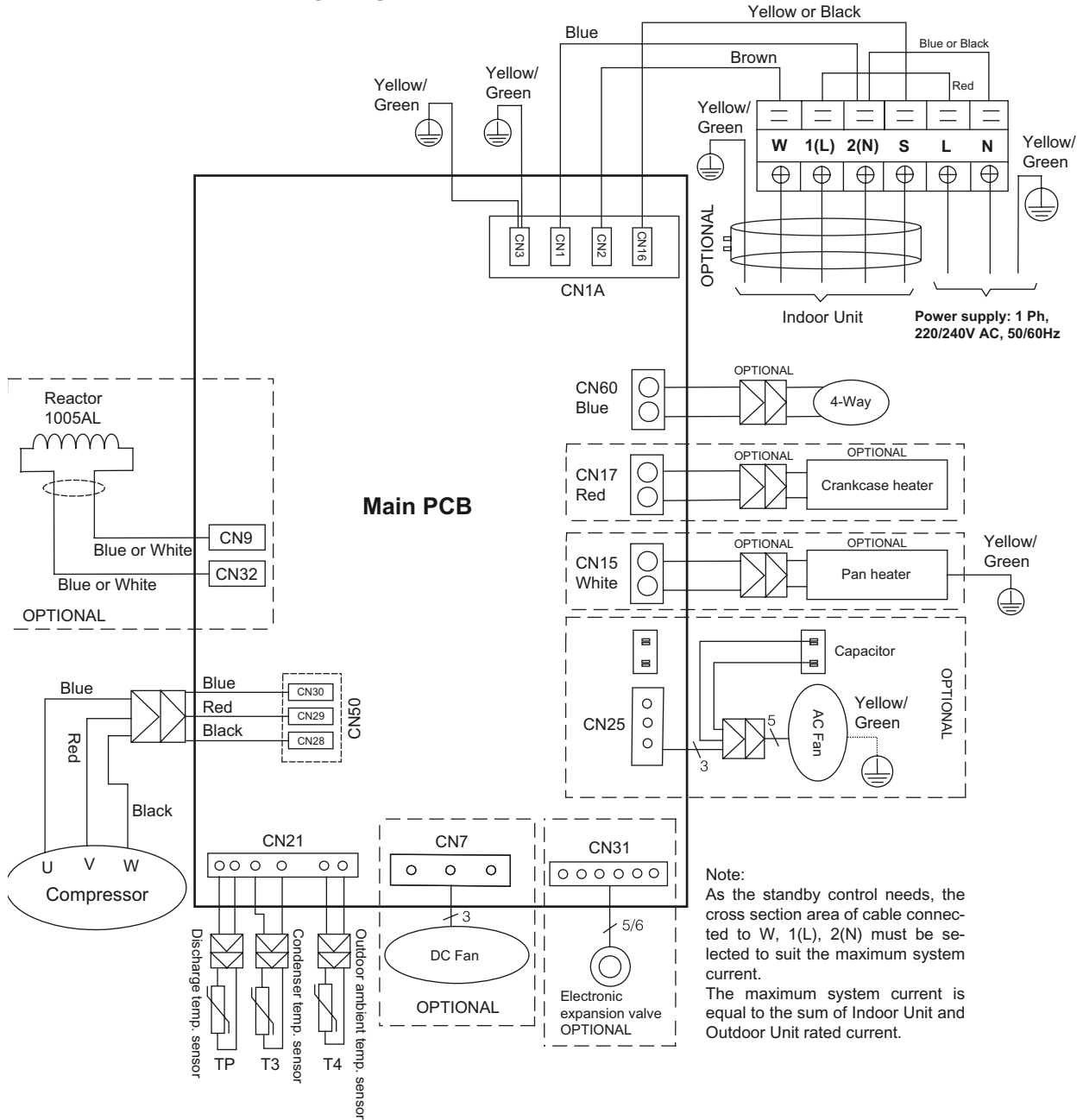

Note:  
As the standby control needs, the cross section area of cable connected to W, 1(L), 2(N) must be selected to suit the maximum system current.  
The maximum system current is equal to the sum of Indoor Unit and Outdoor Unit rated current.

Note: - - - This symbol indicates the element is optional, the actual shape will prevail.

### 3.3 Wiring Diagram abbreviations:

Abbreviation	Paraphrase
Y/G	Yellow-Green Conductor
ION	Positive and Negative Ion Generator
CAP	Capacitor
PLASMA	Electronic Dust Collector
L	LIVE
N	NEUTRAL
Heater	The Electric Heating Belt of Indoor Unit
T1	Indoor Room Temperature
T2	Coil Temperature of Indoor Heat Exchanger
4-WAY	Gas Valve Assembly/4-WAY VALVE
AC-FAN	Alternating Current (AC) FAN
DC-FAN	Direct Current (DC) FAN
CT1	AC Current Detector
COMP	Compressor
T3	Coil Temperature of Condenser
T4	Outdoor Ambient Temperature
TH	Compressor Suction Temperature
TP	Compressor Discharge Temperature
EEV	Electronic Expansion Valve
L-PRO	Low Pressure Switch
H-PRO	High Pressure Switch

3.4 Outdoor Units' Printed Circuit Board Diagram HCNMX 353 / HCNI 533

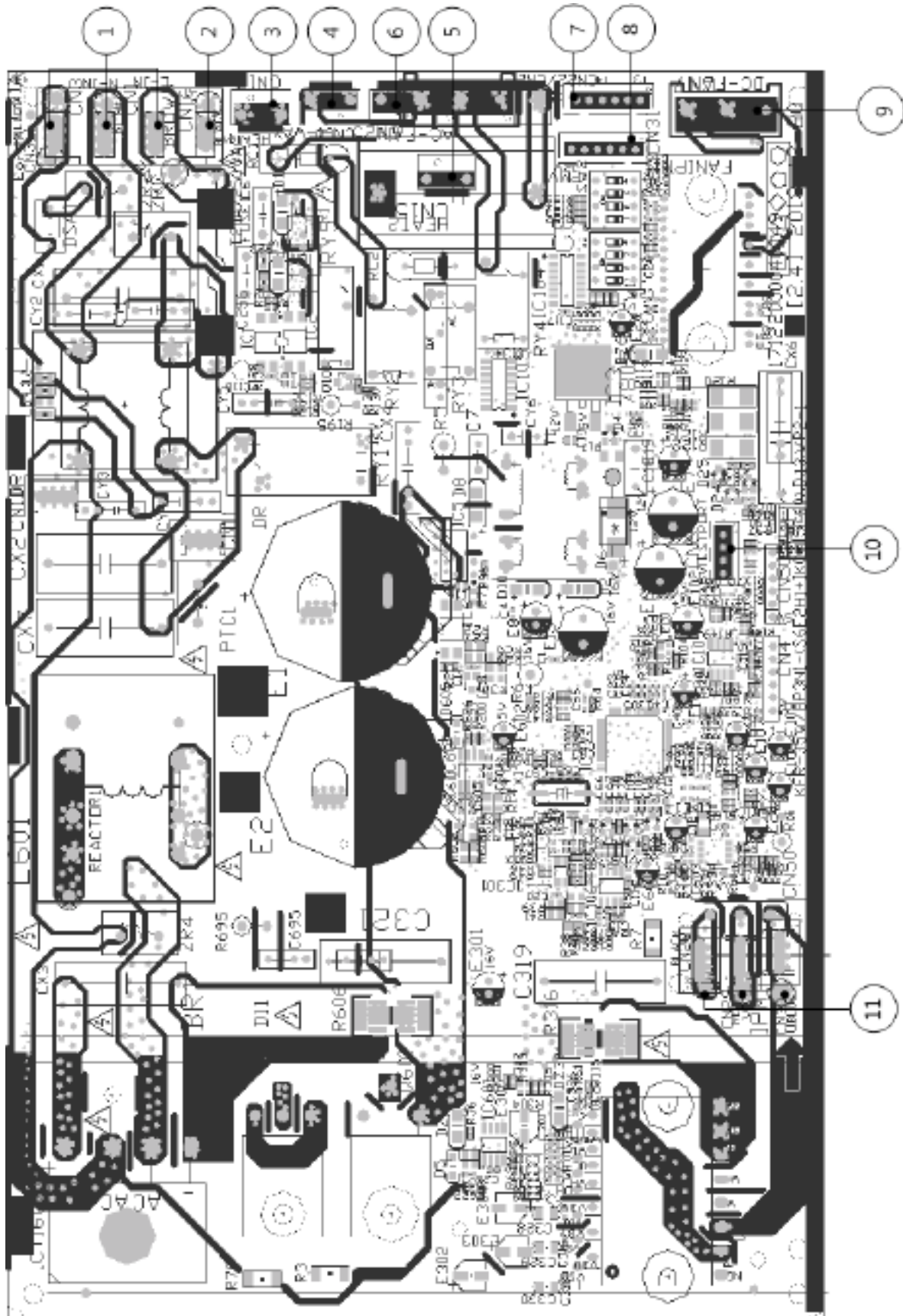



### 3.5 Outdoor Units' Printed Circuit Diagram abbreviations

No.	Name	CN#	Meaning
1	Power Supply	CN3	Earth: connect to Ground.
		CN1	N_in: connect to N-line (208-230V AC input).
		CN2	L_in: connect to L-line (208-230V AC input).
2	S	CN16	S: connect to indoor unit communication.
3	HEAT1	CN17	Connect to compressor heater, 208-230V AC when is ON.
4	4-WAY	CN60	Connect to 4 way valve, 208-230V AC when it is ON.
5	HEAT2	CN15	Connect to chassis heater, 208-230V AC when it is ON.
6	AC-FAN	CN25	Connect to AC fan.
7	TP, T4, T3	CN21/CN22	Connect to pipe temp. sensor T3, ambient temp. sensor T4, exhaust temp. sensor TP.
8	PMV	CN31	Connect to Electric Expansion Valve.
9	DC-FAN	CN7	Connect to DC fan.
10	TESTPORT	CN6	Used for testing.
11	W	CN28	Connect to compressor.
	V	CN29	0V AC (standby).
	U	CN30	10-200V AC (running).

## 4.0 Product features

### 4.1 Display functions

Unit display functions (follow the display type of your purchased product):

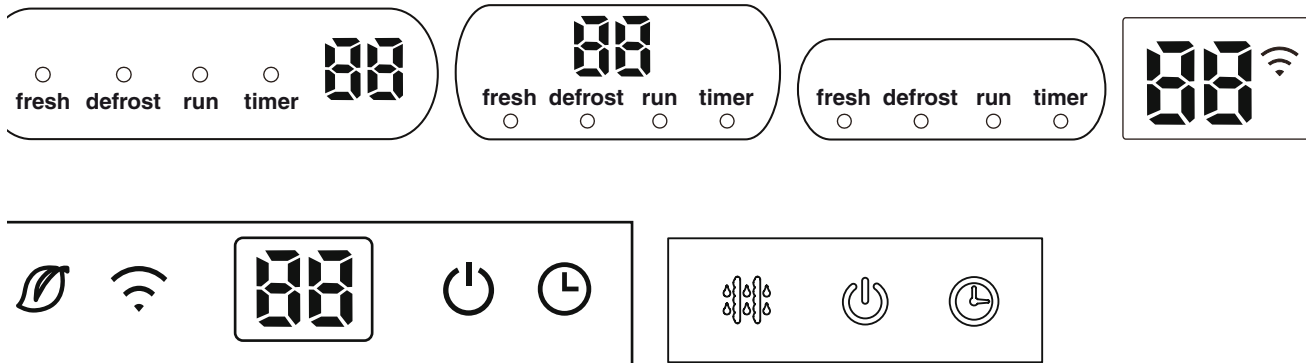

Display	Function	
fresh or	Fresh (available on selected units only).	
defrost or	Defrost.	
run or	When the unit is on.	
timer or	When TIMER is on.	
	WiFi control (available on selected units only).	
	Temperature value	Temperature.
	(3s)	Activation of Timer ON, Fresh, Swing, Turbo, or Silent.
	(3s)	Cancellation of Timer OFF, Fresh, Swing, Turbo, or Silent.
		Defrost.
		Warming in heating mode.
		Self-clean (available on selected units only).
		Heating in room temperature under 8°C.
	gradually illuminates to  in 1 second intervals.	ECO function (available on selected units only).

Note: Please select the display function according to your purchased product.

### 4.2 Safety features

#### Compressor 3-minute delay at restart

Compressor functions are delayed for up to 1 minute upon the first startup of the unit, and are delayed for up to 3 minutes upon subsequent unit restarts.

#### Zero crossing detection error protection (except for DC fan units)

If AC cannot detect zero crossing signal for 4 minutes or the zero crossing signal time interval is not correct, the unit will stop and the LED will display the failure. The correct zero crossing signal time interval should be between 6-13ms.

#### *Automatic shut-off based on discharge temperature*

If the compressor discharge temperature exceeds a certain level for a period of time, the compressor ceases operation.

#### *Automatic shut-off based on fan speed*

If the indoor fan speed registers below 300RPM for an extended period of time, the unit ceases operation and the corresponding error code is displayed on the indoor unit.

#### *Inverter module protection*

The inverter module has an automatic shut-off mechanism based on the unit's current, voltage, and temperature. If automatic shut-off is initiated, the corresponding error code is displayed on the indoor unit and the unit ceases operation.

#### *Indoor fan delayed operation*

- When the unit starts, the louver is automatically activated and the indoor fan will operate after a period of 7 seconds.
- If the unit is in heating mode, the indoor fan is regulated by the anti-cold wind function.

#### *Sensor redundancy and automatic shut-off*

- If one temperature sensor malfunctions, the air conditioner continues operation and displays the corresponding error code, allowing for emergency use.
- When more than one temperature sensor is malfunctioning, the air conditioner ceases operation.

#### *Refrigerant leakage detection*

This function is active only when cooling mode is selected. It will detect if the compressor is being damaged by refrigerant leakage or by compressor overload. This is measured using the coil temperature of evaporator T2 when the compressor is in operation.

### **4.3 Basic functions**

#### *4.3.1 Abbreviation*

Unit element abbreviations:

Abbreviation	Element
T1	Indoor room temperature.
T2	Coil temperature of evaporator.
T3	Coil temperature of condenser.
T4	Outdoor ambient temperature.
TS	Set temperature.
Td	Control target temperature.
TP	Compressor discharge temperature.

In this manual, such as TCE1, TCE2... etc., they are well-setting parameter of EEPROM.

#### *4.3.2 Fan Mode*

When fan mode is activated:

- The outdoor fan and compressor are stopped.
- Temperature control is disabled and no temperature setting is displayed.
- The indoor fan speed can be set to high, medium, low, or auto.
- The louver operations are identical to those in cooling mode.
- Auto fan: In fan-only mode, AC operates the same as auto fan in cooling mode with the temperature set at 24°C.

#### *4.3.3 Cooling Mode*

##### **Compressor Control**

Cooling temperature compensation ( $\Delta T5$ ) is a well-setting parameter of EEPROM. Its value ranges

from  $-2^{\circ}\text{C}$  to  $2^{\circ}\text{C}$ . The default value is 0.

- When  $T1-Ts < \Delta T5-2^{\circ}\text{C}$ , the compressor ceases operation.
- When  $T1-Ts > \Delta T5+3^{\circ}\text{C}$ , the compressor continues operation.
- When the AC is operating in mute (silent) mode, the compressor operates at a low frequency.
- When the current exceeds the preset value, the current protection function activates and the compressor ceases operation.

### Indoor Fan Control

- In cooling mode, the indoor fan operates continuously. The fan speed can be set to high, medium, low, or auto.
- If the compressor ceases operation when the configured temperature is reached, the indoor fan motor operates at the minimum or configured speed.
- The indoor fan is controlled as below:

Setting fan speed	T1-Td °C		Actual fan speed
H	A		H+ (H+ = H+G)
	B		H (H = H)
	C		H- (H- = H-G)
M	D		M+ (M+ = M + Z)
	E		M (M = M)
	F		M- (M- = M - Z)
L	G		L+ (L+ = L+D)
	H		L (L = L)
	I		L- (L- = L - D)

- The auto fan acts as below rules:

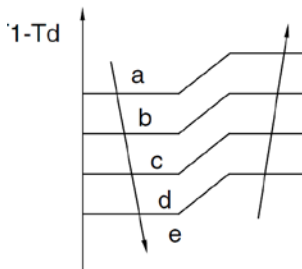

### Outdoor Fan Control

- The outdoor unit will be run at different fan speed according to T4 and compressor frequency.
- For different outdoor units, the fan speeds are different.

### Condenser Temperature Protection

When condenser temperature is higher than setting value, the compressor ceases operation.

### Evaporator Temperature Protection

When evaporator temperature drops below a configured value, the compressor and outdoor fan cease operation.

#### 4.3.4 Heating Mode

### Compressor Control

Heating temperature compensation ( $\Delta T3$ ) is a well-setting parameter of EEPROM. Its value ranges from  $-6^{\circ}\text{C}$  to  $6^{\circ}\text{C}$ .

- When  $T1-Ts > -\Delta T3$ , the compressor ceases operation.
- When  $T1-Ts < -\Delta T3-1.5^{\circ}\text{C}$ , the compressor continues operation.
- When the AC is operating in mute (silent) mode, the compressor operates at a low frequency.
- When the current exceeds the preset value, the current protection function activates and the compressor ceases operation.

### Indoor Fan Control

- When the compressor is on, the indoor fan speed can be set to high, medium, low, or auto.

And the anti-cold wind function has the priority.

- Anti-cold air function:
  - The indoor fan is controlled by the indoor temperature T1 and indoor unit coil temperature T2.

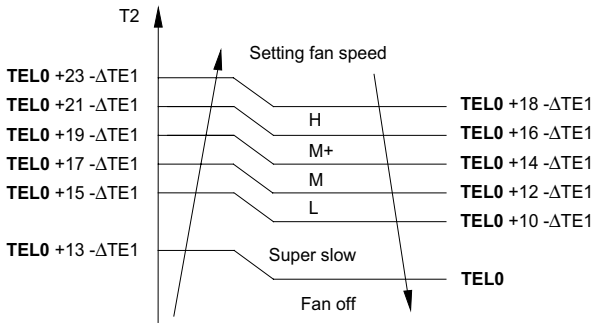

$T1 \geq 19^{\circ}\text{C}$	$\Delta TE1 = 0$
$15^{\circ}\text{C} \leq T1 \leq 18^{\circ}\text{C}$	$\Delta TE1 = 19^{\circ}\text{C} - T1$
$T1 < 15^{\circ}\text{C}$	$\Delta TE1 = 4^{\circ}\text{C}$

- When the indoor temperature T1 reaches the setting temperature, the compressor will stop, the indoor fan motor runs at the minimum speed or setting speed. (The anti-cold air function is valid).
- The indoor fan is controlled as below:

Setting fan speed	T1-Td °C	Actual fan speed
H		H- (H- = H-G)
		H (H = H)
		H+ (H+ = H+G)
M		M- (M- = M - Z)
		M (M = M)
		M+ (M+ = M + Z)
L		L- (L- = L - D)
		L (L = L)
		L+ (L+ = L+D)

- Auto fan action in heating mode:

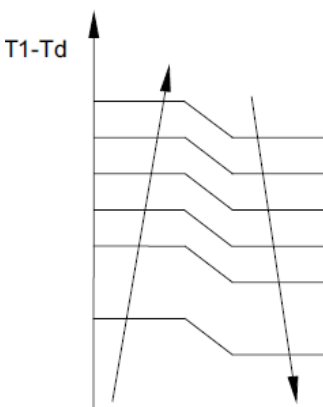

**Outdoor Fan Control:**

- The outdoor unit will be run at different fan speed according to T4 and compressor frequency.
- For different outdoor units, the fan speeds are different.

**Defrosting mode**

- The unit enters defrosting mode according to the temperature value of T3 and T4 as well as

the compressor running time.

- In defrosting mode, the compressor continues to run, the indoor and outdoor motor will cease operation, the defrost light of the indoor unit will turn on, and the “**df**” symbol is displayed.
- If any one of the following conditions is satisfied, defrosting ends and the machine switches to normal heating mode:
  - T3 rises above TCDE1.
  - T3 maintained above TCDE2 for 80 seconds.
  - Unit runs for 15 minutes consecutively in defrosting mode.

### Evaporator Temperature Protection

When the evaporator temperature exceeds a preset protection value, the compressor ceases operation.

#### 4.3.5 Auto Mode

- This mode can be selected with the remote controller and the setting temperature can be changed between 17°C-30°C.
- In auto mode, the machine selects cooling, heating, or fan-only mode on the basis of  $\Delta T$  ( $\Delta T = T1 - T5$ ).

$\Delta T$	Running mode
$\Delta T > A$	Cooling
$B^{\circ}C \leq \Delta T \leq A$	Fan-only
$\Delta T > B$	Heating*

(Heating\*: In auto mode, cooling only models run the fan.)

- Indoor fan will run at auto fan speed.
- The louver operates same as in relevant mode.
- If the machine switches mode between heating and cooling, the compressor will keep stopping for certain time and then choose mode according to  $\Delta T$ .

#### 4.3.6 Drying Mode

- Indoor fan speed is fixed at breeze and can't be changed. The louver angle is the same as in cooling mode.
- All protections are active and the same as that in cooling mode.

#### 4.3.7 Forced operation function

Press the AUTO/COOL button, the AC will run as in below sequence:

Forced auto > Forced cooling > Off



- Forced cooling mode: The compressor and outdoor fan continue to run and the indoor fan runs at breeze speed. After running for 30 minutes, the AC will switch to auto mode with a preset temperature of 24°C.
- Forced auto mode: Forced auto mode operates the same as normal auto mode with a preset temperature of 24°C.
- The unit exits forced operation when it receives the following signals:
  - Switch on.
  - Switch off.
  - Timer on.
  - Timer off.
  - Changes in:
    - Mode.
    - Fan speed.
    - Sleep mode.
    - Follow me.

- Forced defrosting mode:
- Press AUTO/COOL button continuously for 5 sec. under forced cooling mode to enter this mode.
- Indoor fan will stop, defrosting lamp will light on.
- Quit this mode and turn off the unit when:
  - Quit normal defrosting.
  - Turn off by RC.
  - Press AUTO/COOL button continuously for 5 sec. again.

#### 4.3.8 Sleep function

- The sleep function is available in cooling, heating, or auto mode.
- The operational process for sleep mode is as follows:
  - When cooling, the temperature rises 1°C (to not higher than 30°C) every hour. After 2 hours, the temperature stops rising and the indoor fan is fixed at low speed.
  - When heating, the temperature decreases 1°C (to not lower than 17°C) every hour. After 2 hours, the temperature stops decreasing and the indoor fan is fixed at low speed. Anti-cold wind function takes priority.
- The operating time for sleep mode is 8 hours, after which the unit exits this mode and does not switch off.

#### 4.3.9 Auto-Restart function

- The indoor unit has an auto-restart module that allows the unit to restart automatically. The module automatically stores the current settings (not including the swing setting) and, in the case of a sudden power failure, it will restore those setting automatically within 3 minutes after power returns.
- If the unit was in forced cooling mode, it will run in this mode for 30 minutes and turn to auto mode with temperature set to 24°C.
- If there is a power failure while the unit is running, the compressor starts 3 minutes after the unit restarts. If the unit was already off before the power failure, the compressor starts 1 minute after the unit restarts.

#### 4.3.10 Refrigerant Leakage Detection

With this new technology, the display area will show “EC” when the outdoor unit detects refrigerant leakage.

#### 4.3.11 Ionizer / Plasma (for some models)

Press “Fresh” for at least 2 seconds on the remote control to enable the IONIZER function. While this function is active, the Ionizer / Plasma Dust Collector (depending on models) is energized and will help to remove pollen and impurities from the air.

### 4.4 Optional functions

#### 4.4.1 8°C Heating

In heating mode, the temperature can be set to as low as 8°C, preventing the indoor area from freezing if unoccupied during severe cold weather.

#### 4.4.2 Self Clean

- If you press “Self Clean” when the unit is in cooling or drying mode:
  - For cooling only models, the indoor unit will run in low fan mode for a certain time, then ceases operation.
  - For heat pump models, the indoor unit will run in fan-only mode, then low heat, and finally in fan-only mode.
- Self Clean function keeps the indoor unit dry and prevents mold growth.
- When match with multi outdoor unit, this function is disabled.

#### 4.4.3 *Follow Me*

- If you press “Follow Me” on the remote, the indoor unit will beep. This indicates the follow me function is active.
- Once active, the remote control will send a signal every 3 minutes, with no beeps. The unit automatically sets the temperature according to the measurements from the remote control temperature sensor.
- The unit will only change modes if the information from the remote control makes it necessary, not from the unit’s temperature setting.
- If the unit does not receive a signal for 7 minutes or you press “Follow Me,” the function turns off. The unit regulates temperature based on its own sensor and settings.

#### 4.4.4 *SILENCE*

- Press “Silence” on the remote control to enable the SILENCE function. While this function is active, the compressor frequency is maintained at a lower level than F2. The indoor unit will run at faint breeze, which reduces noise to the lowest possible level.
- When indoor unit is matched with multi outdoor unit, this function is disabled.

## 5.0 Maintenance

### 5.1 *First time installation check*

Air and moisture trapped in the refrigerant system affects the performance of the air conditioner by:

- Increasing pressure in the system.
- Increasing the operating current.
- Decreasing the cooling or heating efficiency.
- Congesting the capillary tubing due to ice build-up in the refrigerant circuit.
- Corroding the refrigerant system.

To prevent air and moisture from affecting the air conditioner’s performance, the indoor unit, as well as the pipes between the indoor and outdoor unit, must be be leak tested and evacuated.

Leak test (soap water method):

Use a soft brush to apply soapy water or a neutral chlorine-free liquid detergent onto the indoor unit connections and outdoor unit connections. If there is gas leakage, bubbles will form on the connection.



## Air purging with vacuum pump:

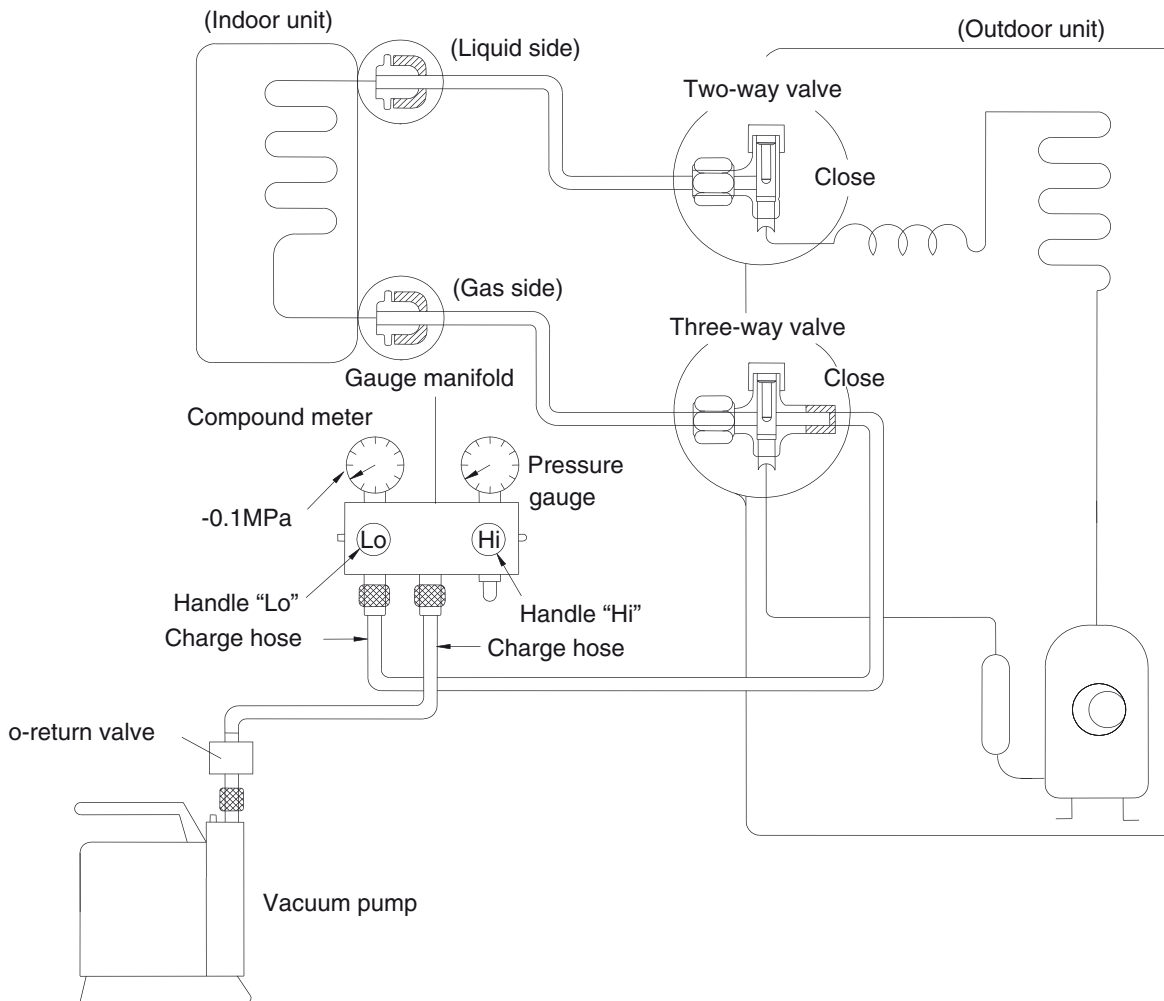

### Procedure:

1. Tighten the flare nuts of the indoor and outdoor units, and confirm that both the 2-way and 3-way valves are closed.
2. Connect the charge hose with the push pin of Handle "Lo" to the gas service port of the 3-way valve.
3. Connect another charge hose to the vacuum pump.
4. Fully open the Handle "Lo" manifold valve.
5. Using the vacuum pump, evacuate the system for 30 minutes.
  - a. Check whether the compound meter indicates -0.1 MPa (14.5 Psi).
    - If the meter does not indicate -0.1 MPa (14.5 Psi) after 30 minutes, continue evacuating for an additional 20 minutes.
    - If the pressure does not achieve -0.1 MPa (14.5 Psi) after 50 minutes, check for leakage.
    - If the pressure successfully reaches -0.1 MPa (14.5 Psi), fully close the Handle "Lo" valve, then cease vacuum pump operations.
  - b. Wait for 5 minutes then check whether the gauge needle moves after turning off the vacuum pump. If the gauge needle moves backward, check whether there is gas leakage.
6. Loosen the flare nut of the 3-way valve for 6 or 7 seconds and then tighten the flare nut again.
  - a. Confirm the pressure display in the pressure indicator is slightly higher than the atmospheric pressure.
  - b. Remove the charge hose from the 3-way valve.
7. Fully open the 2-way and 3-way valves and tighten the cap of the 2-way and 3-way valves.

## 5.2 Refrigerant recharge

Adding the refrigerant if the piping length exceeds the chargeless pipe length:

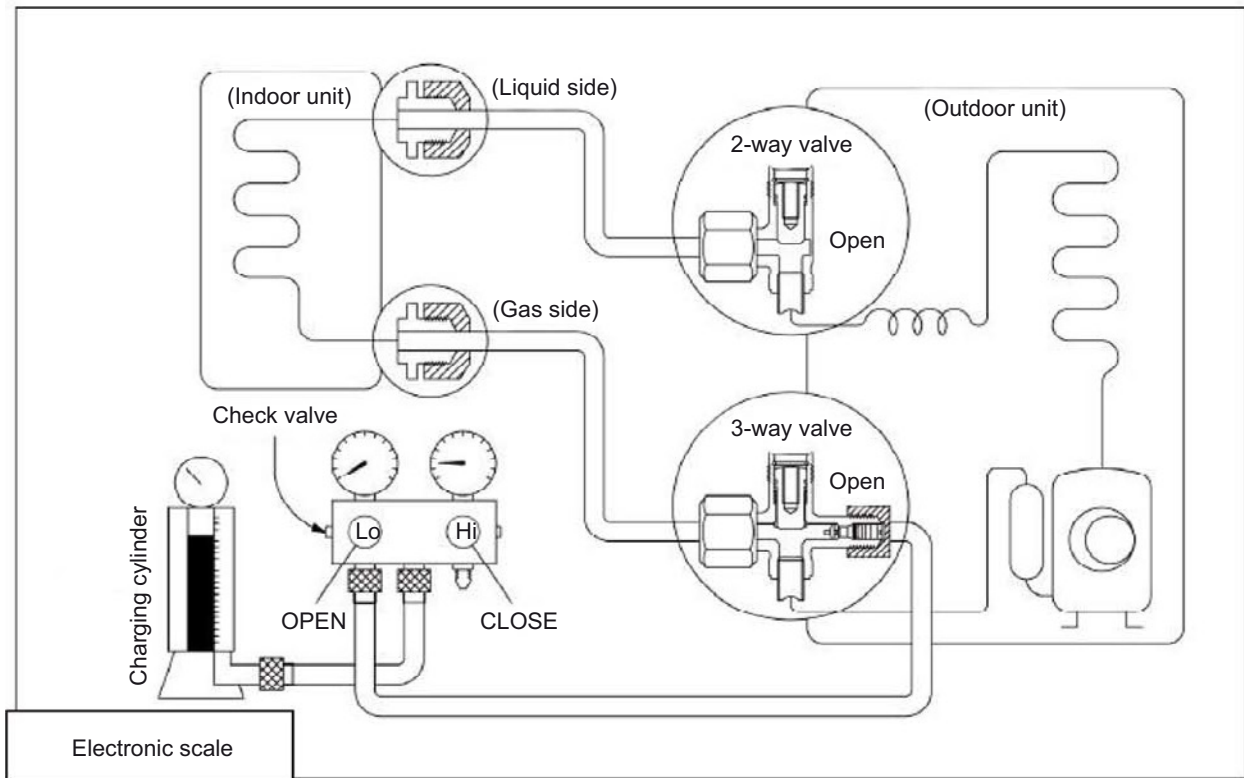

Procedure:

1. Close both 2-way and 3-way valves.
2. Slightly connect the Handle "Lo" charge hose to the 3-way service port.
3. Connect the charge hose to the valve at the bottom of the cylinder.
4. As the refrigerant is R32, invert the cylinder to ensure a complete liquid charge.
5. Open the valve at the bottom of the cylinder for 5 seconds to purge the air in the charge hose, then fully tighten the charge hose with push pin Handle "Lo" to the service port of 3-way valve.
6. Place the charging cylinder onto an electronic scale and record the starting weight.
7. Fully open the Handle "Lo" manifold valve, 2-way and 3-way valves.
8. Operate the air conditioner in cooling mode to charge the system with liquid refrigerant.
9. When the electronic scale displays the correct weight (refer to the gauge and the pressure of the low side to confirm, the value of pressure refers to the Appendix, turn off the air conditioner, then disconnect the charge hose from the 3-way service port immediately.
10. Mount the caps of service port and 2-way and 3-way valves.
11. Use a torque wrench to tighten the caps to a torque of 18 N•m.
12. Check for gas leakage.

### 5.3 Re-installation

#### 5.3.1 Indoor Unit

Collecting the refrigerant into the outdoor unit:

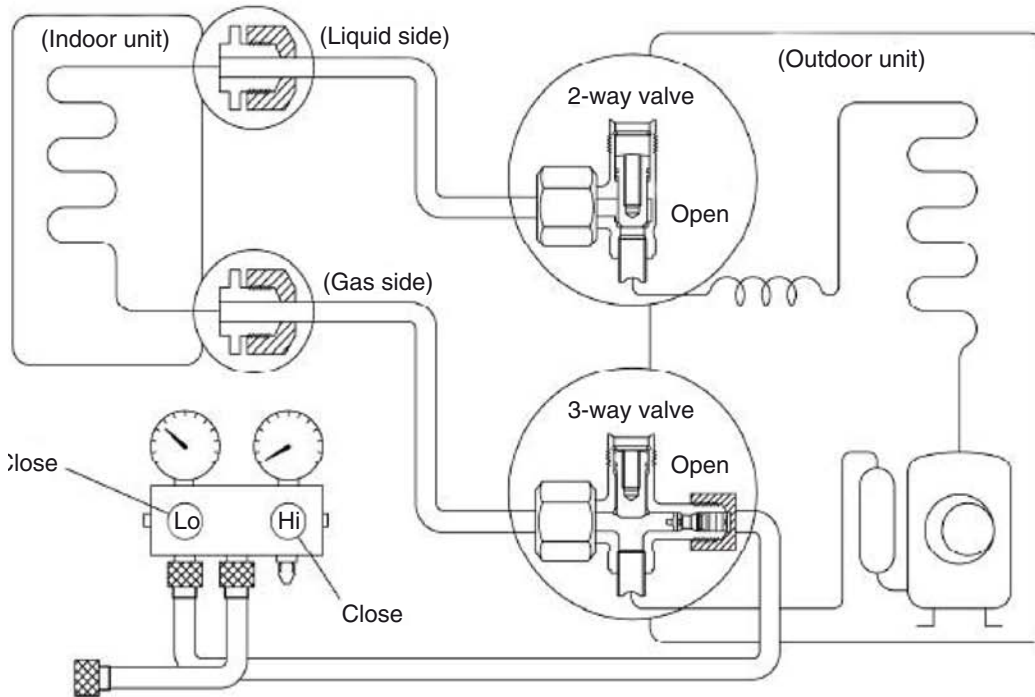

Procedure:

1. Confirm that the 2-way and 3-way valves are opened.
2. Connect the charge hose with the push pin of Handle "Lo" to the 3-way valve's gas service port.
3. Open the Handle "Lo" manifold valve to purge air from the charge hose for 5 seconds and then close it quickly.
4. Close the 2-way valve.
5. Operate the air conditioner in cooling mode. Cease operations when the gauge reaches 0.1 MPa (14.5 Psi).
6. Close the 3-way valve so that the gauge rests between 0.3 MPa (43.5 Psi) and 0.5 MPa (72.5 Psi).
7. Disconnect the charge set and mount the caps of service port and 2-way and 3-way valves.
8. Use a torque wrench to tighten the caps to a torque of 18 N•m.
9. Check for gas leakage.

## Air purging with vacuum pump:

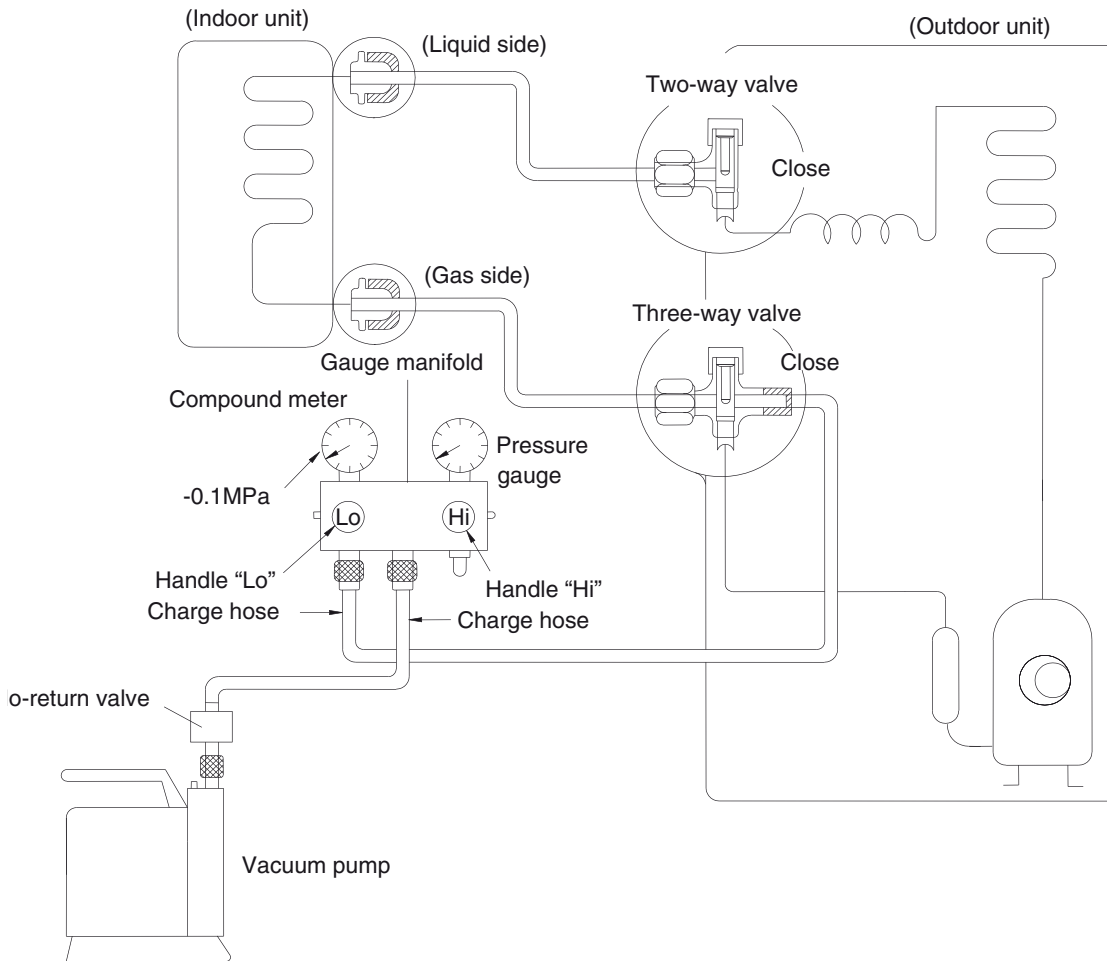

### Procedure:

1. Tighten the flare nuts of the indoor and outdoor units, and confirm that both the 2-way and 3-way valves are closed.
2. Connect the charge hose with the push pin of Handle "Lo" to the gas service port of the 3-way valve.
3. Connect another charge hose to the vacuum pump.
4. Fully open the Handle "Lo" manifold valve.
5. Using the vacuum pump, evacuate the system for 30 minutes.
  - a. Check whether the compound meter indicates -0.1 MPa (14.5 Psi).
    - If the meter does not indicate -0.1 MPa (14.5 Psi) after 30 minutes, continue evacuating for an additional 20 minutes.
    - If the pressure does not achieve -0.1 MPa (14.5 Psi) after 50 minutes, check for leakage.
    - If the pressure successfully reaches -0.1 MPa (14.5 Psi), fully close the Handle "Lo" valve, then cease vacuum pump operations.
  - b. Wait for 5 minutes then check whether the gauge needle moves after turning off the vacuum pump. If the gauge needle moves backward, check whether there is gas leakage.
6. Loosen the flare nut of the 3-way valve for 6 or 7 seconds and then tighten the flare nut again.
  - a. Confirm the pressure display in the pressure indicator is slightly higher than the atmospheric pressure.
  - b. Remove the charge hose from the 3-way valve.
7. Fully open the 2-way and 3-way valves and tighten the cap of the 2-way and 3-way valves.

### 5.3.2 Outdoor Unit

Evacuation for the whole system:

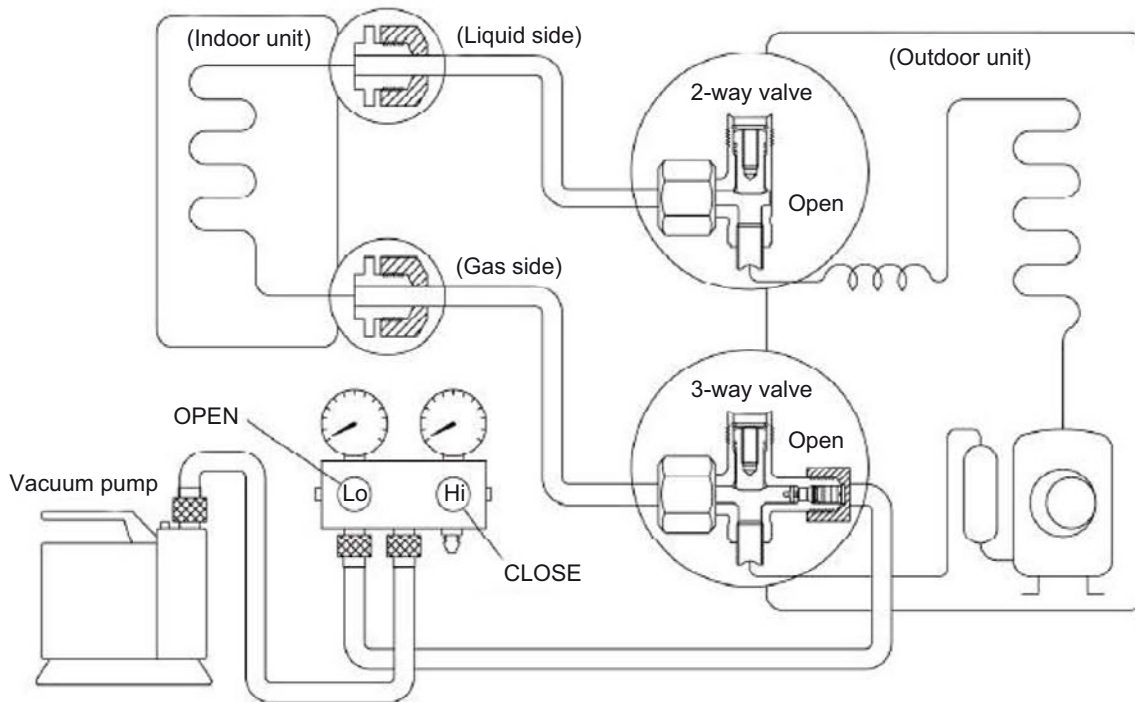

#### Procedure:

1. Confirm that the 2-way and 3-way valves are opened.
2. Connect the vacuum pump to the 3-way valve's service port.
3. Evacuate the system for approximately 1 hour. Confirm that the compound meter indicates -0.1 MPa (14.5Psi).
4. Close the valve (Low side) on the charge set and turn off the vacuum pump.
5. Wait for 5 minutes then check whether the gauge needle moves after turning off the vacuum pump. If the gauge needle moves backward, check whether there is gas leakage.
6. Disconnect the charge hose from the vacuum pump.
7. Mount the caps of service port and 2-way and 3-way valves.
8. Use a torque wrench to tighten the caps to a torque of 18 N•m.

## Refrigerant charging:

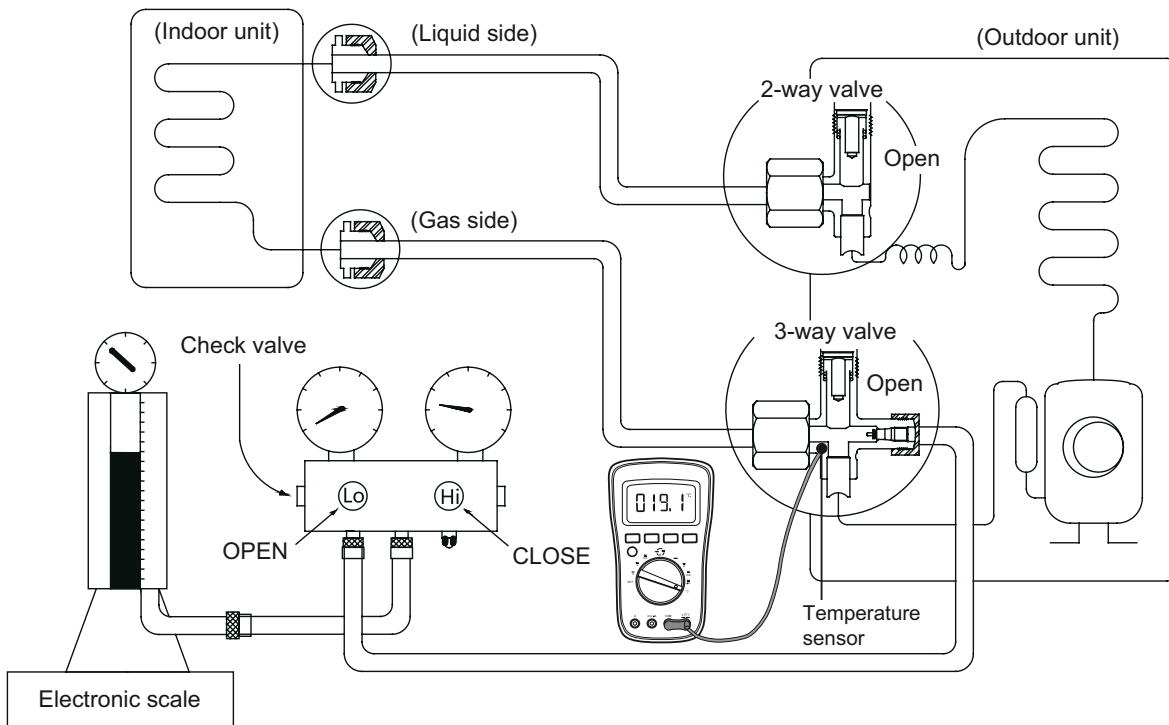

### Procedure:

1. Close both 2-way and 3-way valves.
2. Slightly connect the Handle "Lo" charge hose to the 3-way service port.
3. Connect the charge hose to the valve at the bottom of the cylinder.
4. As the refrigerant is R32, invert the cylinder to ensure a complete liquid charge.
5. Open the valve at the bottom of the cylinder for 5 seconds to purge the air in the charge hose, then fully tighten the charge hose with push pin Handle "Lo" to the service port of 3-way valve.
6. Place the charging cylinder onto an electronic scale and record the starting weight.
7. Fully open the Handle "Lo" manifold valve, 2-way and 3-way valves.
8. Operate the air conditioner in cooling mode to charge the system with liquid refrigerant.
9. When the electronic scale displays the correct weight (refer to the gauge and the pressure of the low side to confirm, the value of pressure refers to the Appendix, turn off the air conditioner, then disconnect the charge hose from the 3-way service port immediately.
10. Mount the caps of service port and 2-way and 3-way valves.
11. Use a torque wrench to tighten the caps to a torque of 18 N•m.
12. Check for gas leakage.

### Notes:

1. Mechanical connectors used indoors shall comply with local regulations.
2. When mechanical connectors are reused indoors, sealing parts shall be renewed. When flared joints are reused indoors, the flare part shall be re-fabricated.

# 6.0 Indoor Units Disassembly

## 6.1 Indoor Units Dimensions

Type	a	b	c
HKEU 353	805	194	285
HKEU 533	957	213	302

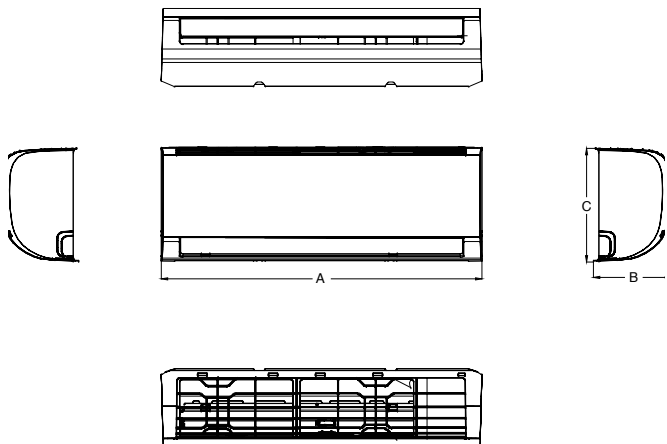

## 6.2 Disassembling the indoor unit

### 6.2.1 Front Panel

Procedure	Illustration
1) Hold the front panel by the tabs on the both sides and lift it.	<p>The illustration shows a hand lifting the front panel from the indoor unit. A dashed line points to the top of the panel labeled 'Front Panel'. Another dashed line points to the side tabs labeled 'Tab'. An arrow indicates the upward movement.</p>
2) Push up the bottom of an air filter, and then pull it out downwards.	<p>The illustration shows a hand pushing up the bottom of the air filter. A dashed line points to the filter labeled 'Filter'. An arrow indicates the downward movement of the filter.</p>
3) Open the horizontal louver and push the hook towards left to open it.	<p>The illustration shows the horizontal louver being opened. A dashed line points to the louver labeled 'Horizontal Louver'. A circular inset shows a close-up of a hand pushing a hook to the left, with a dashed line pointing to the hook labeled 'Hook'. An arrow indicates the leftward movement.</p>

4) Bend the horizontal louver lightly by both hands to loosen the hooks, then remove the horizontal louver.

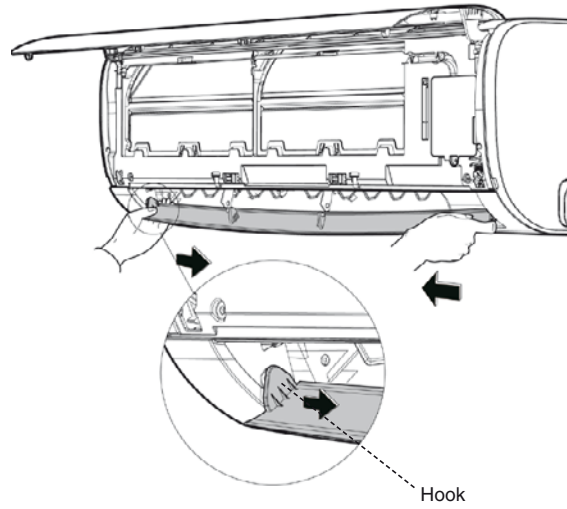

5) Remove 1 screw and then remove the electrical cover.

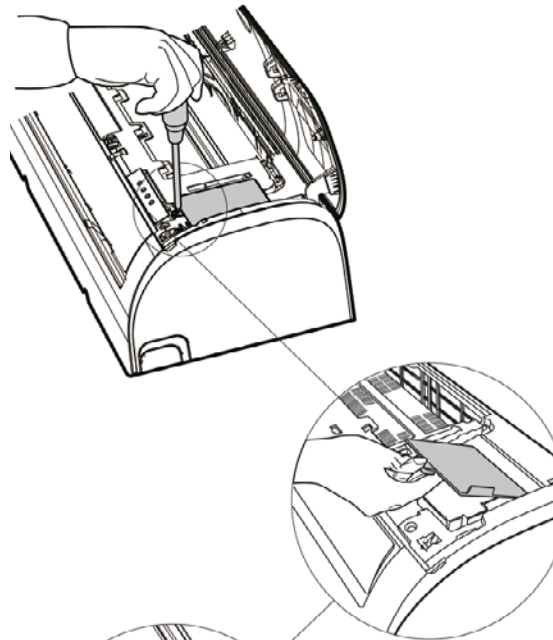

6) Disconnect the connector for the display board.



7) Remove the display board.

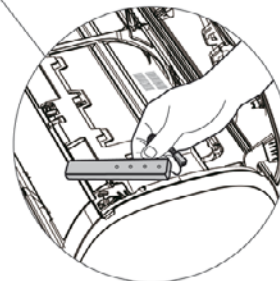



8) Open the screw caps (2) and then remove the screws.

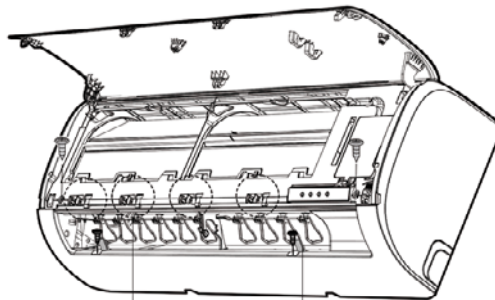

9) Release the 4 hooks.

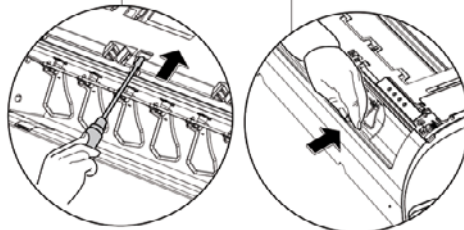

10) Release the seven hooks in the back.

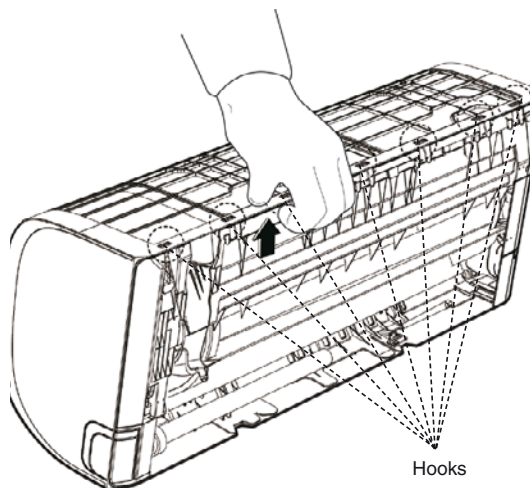

11) Pull out the panel frame while pushing the hook through a clearance between the panel frame and the heat exchanger.

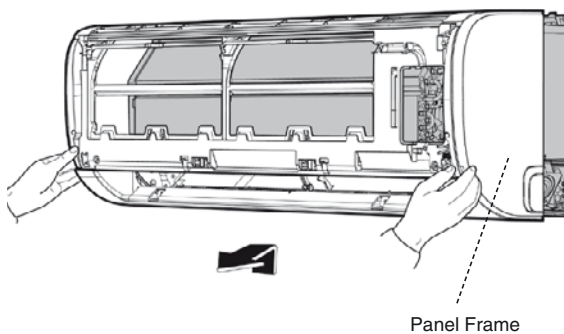

### 6.2.2 Electrical parts (antistatic gloves must be worn)

Note: Remove the front panel before disassembling electrical parts.

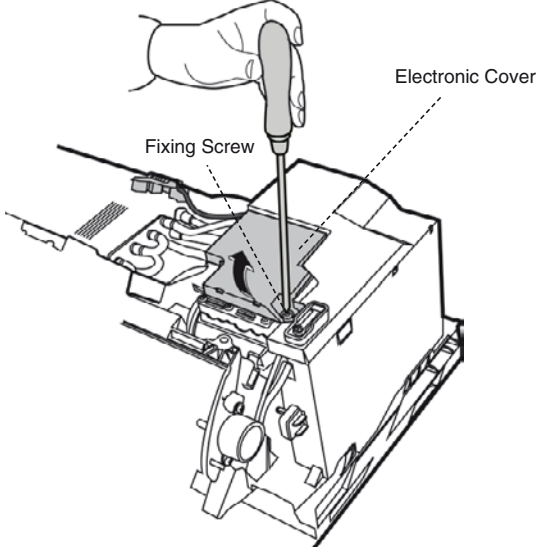
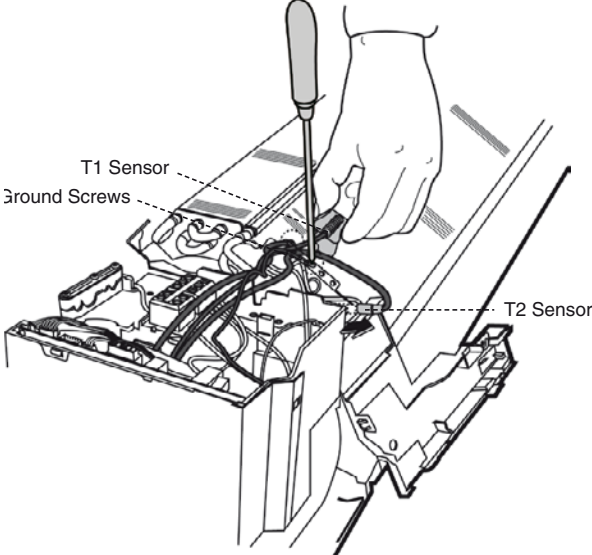
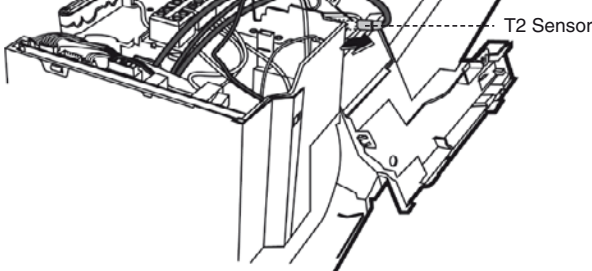
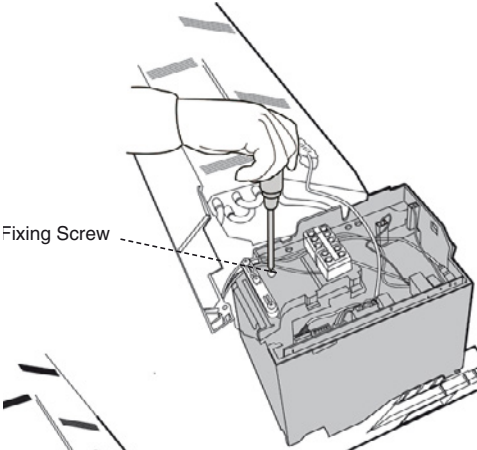
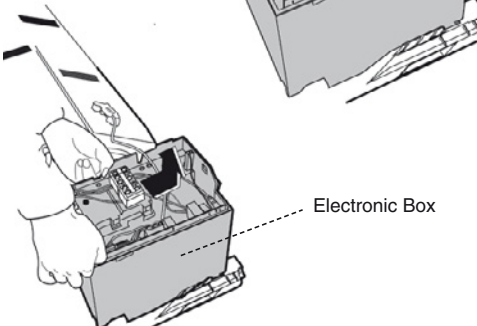
Procedure	Illustration
1) Remove the fixing screw and then remove the cover of electronic box and the terminal cover.	
2) Pull out the room temperature sensor (T1) and the coil temperature sensor (T2).	
3) Remove the 2 screws used for the ground connection.	
4) Remove the fixing screw.	
5) Pull out the Electrical control box along the direction indicated in right image to remove it.	

6) Disconnect the wires. Then remove the electronic main board.

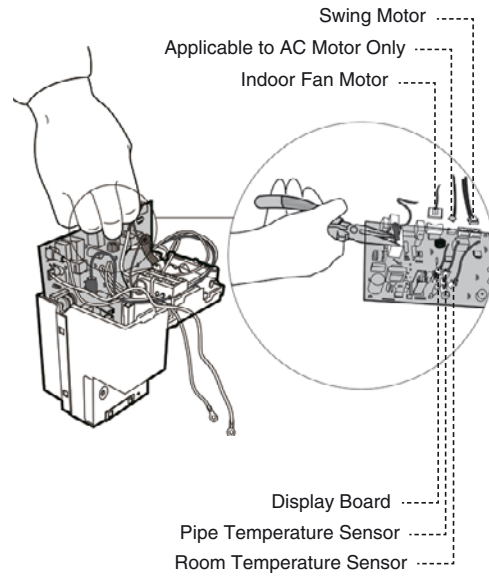

7) Remove the fixing screw, then remove the capacitor of fan motor.

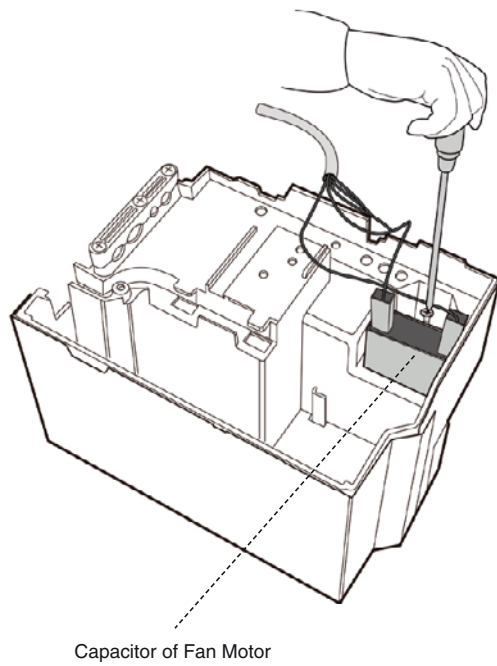

### 6.2.3 Evaporator

Note: Remove the front panel and electrical parts before disassembling evaporator.

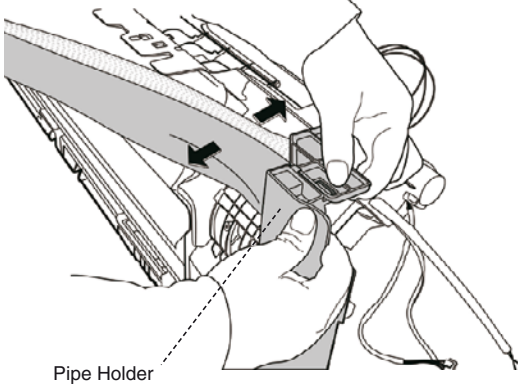
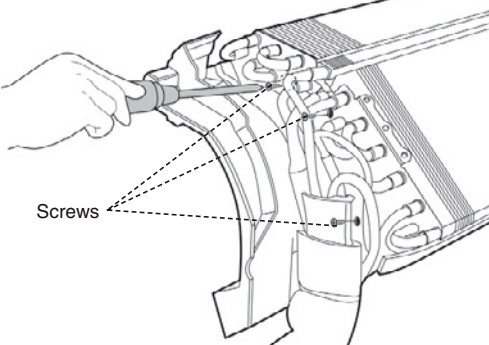
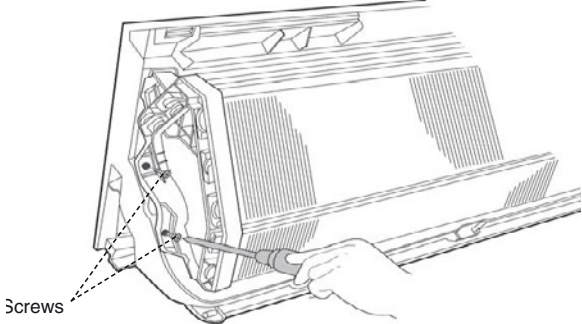
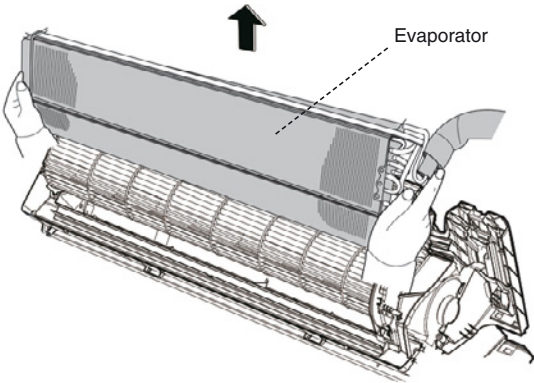
Procedure	Illustration
1) Disassemble the pipe holder located at the rear of the unit.	 <p>Pipe Holder</p>
2) Remove the screws on the evaporator located at the fixed plate.	 <p>Screws</p>
3) Remove the two screws on the evaporator located at the base of the bearing side.	 <p>Screws</p>
4) Pull out the evaporator.	 <p>Evaporator</p>

### 6.2.4 Fan motor and fan

Note: Remove the front panel, electrical parts and evaporator before disassembling fan motor and fan.

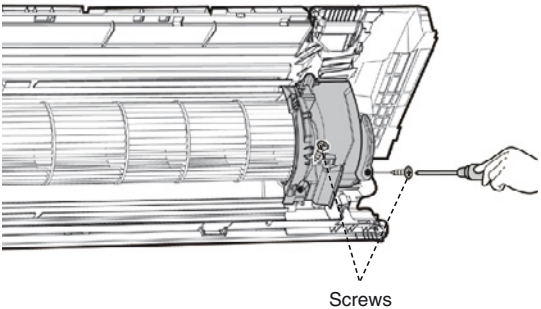
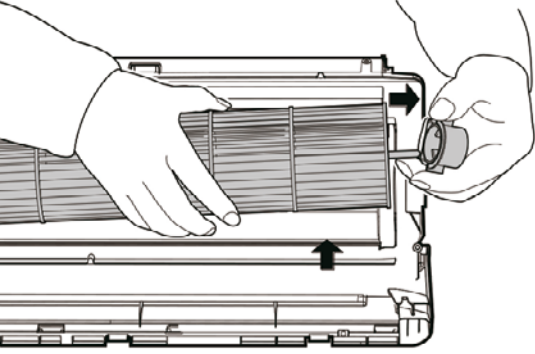
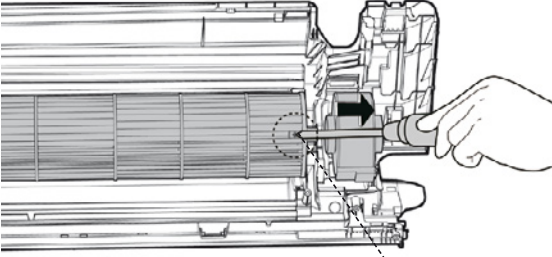
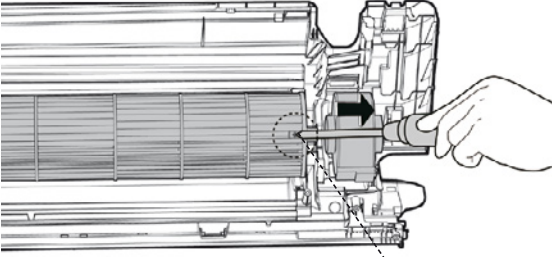
Procedure	Illustration
1) Remove the two screws and remove the fixing board of the fan motor.	 <p>Screws</p>
2) Remove the Bearing sleeve.	
3) Remove the fixing screw.	
4) Pull out the fan motor and fan assembly from the side.	 <p>Fixing Screw</p>

### 6.2.5 Step motor

Note: Remove the front panel and electrical parts before disassembling step motor.

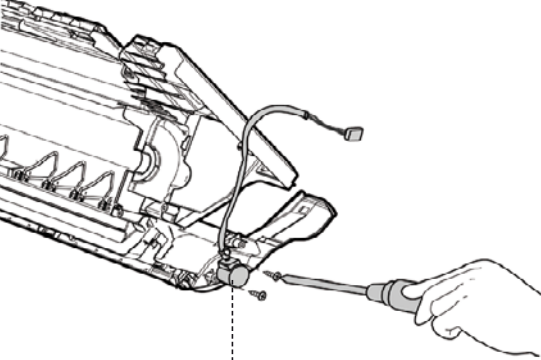
Procedure	Illustration
1) Remove the 2 screws, then remove the stepping motor.	 <p>Stepping Motor</p>

# 7.0 Outdoor Units Disassembly

## 7.1 Outdoor Units Dimensions

Type	a	b	c	d	e	f	g	h	i	j	k	l	m	n	o	p
HCMX 353	720	270	495	7.6	727	452	70	87	60	281	245	33	256	49	11	76.5
HCNI 533	800	333	554	12.0	815	514	70	85.5	60	365	311	62	340	20	61.6	106

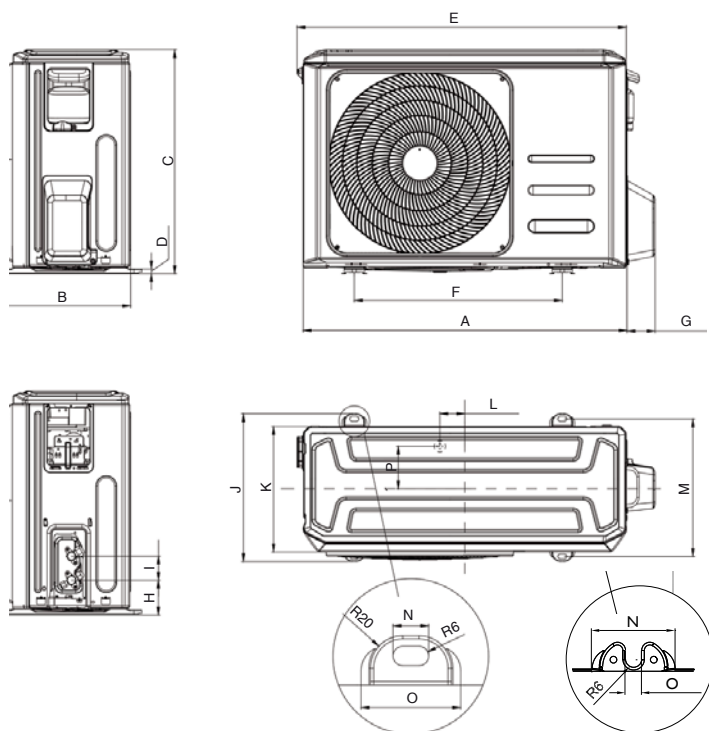

## 7.2 Disassembling the outdoor unit

### 7.2.1 Panel Plate

#### Model 353

Procedure	Illustration
<p>1) Turn off the air conditioner and the power breaker.</p>	<p>Big Handle</p>
<p>2) Remove the screws of the big handle and then remove the big handle (1 screw).</p>	

3) Remove the screws of the top cover and then remove the top cover (3 screws). One of the screws is located underneath the big handle.

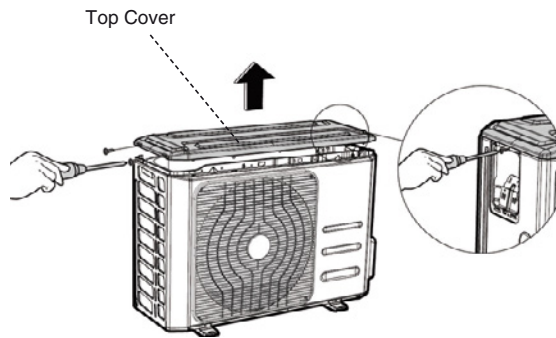

4) Remove the screws of the front panel and then remove the front panel (6 screws).

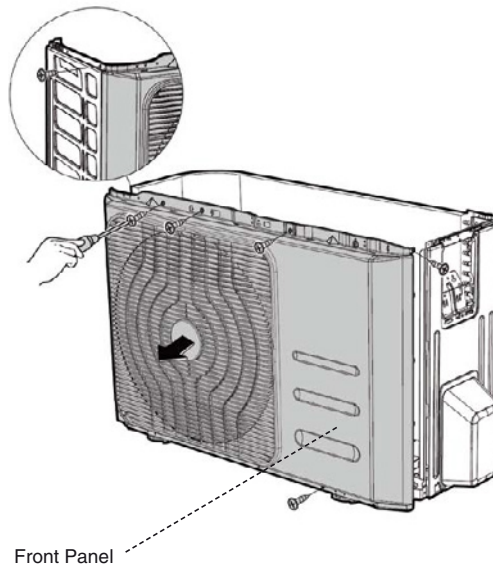

5) Remove the screws of water collecting cover (2 screws).

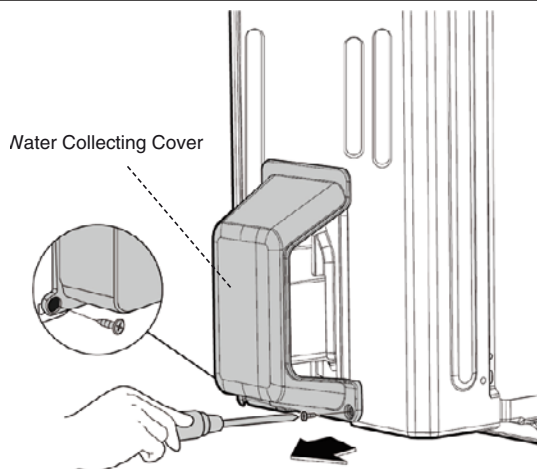

6) Remove the screws of the rear net and then remove the rear net (2 screws) (for some models).

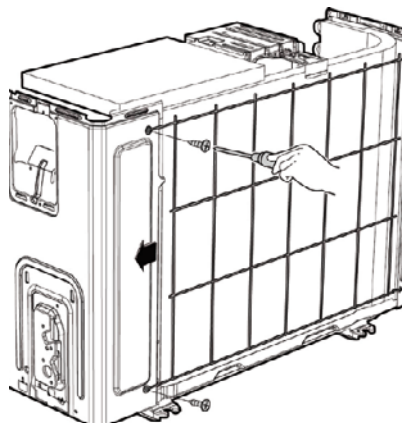

7) Remove the screws of the right panel and then remove the right panel (6 screws).

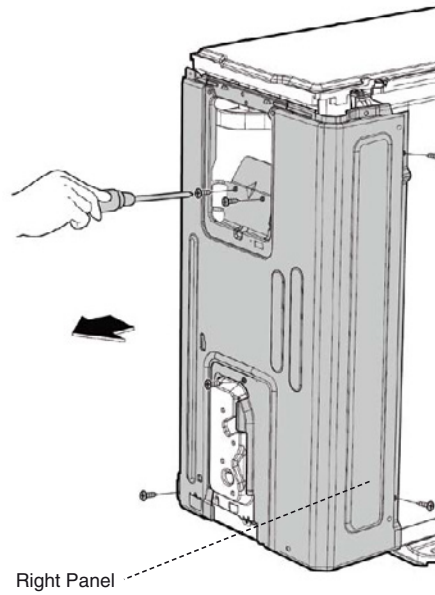

### Model 533

Procedure	Illustration
1) Turn off the air conditioner and the power breaker.	<p>Big Handle</p>
2) Remove the screws of the big handle and then remove the big handle (1 screws).	<p>Top Cover</p>



4) Remove the screws of the front panel and then remove the front panel (8 screws).

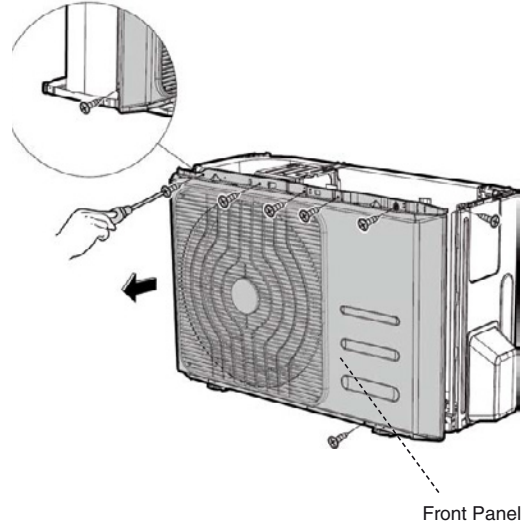

5) Remove the screws of water collecting cover and then remove the water collecting cover (2 screws).

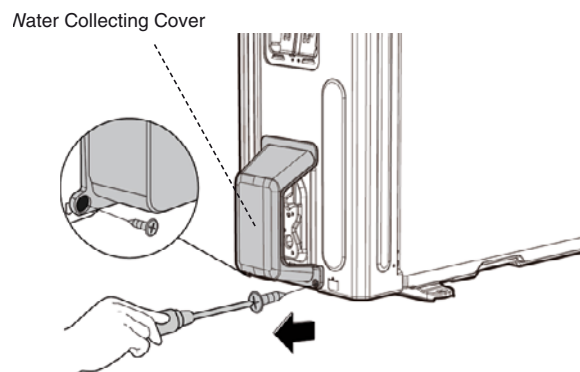

6) Remove the screws of the rear net and then remove the rear net (2 screws) (for some models).

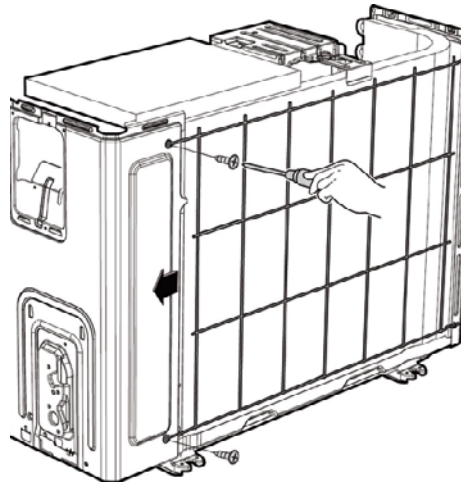

7) Remove the screws of the right panel and then remove the right panel (5 screws).

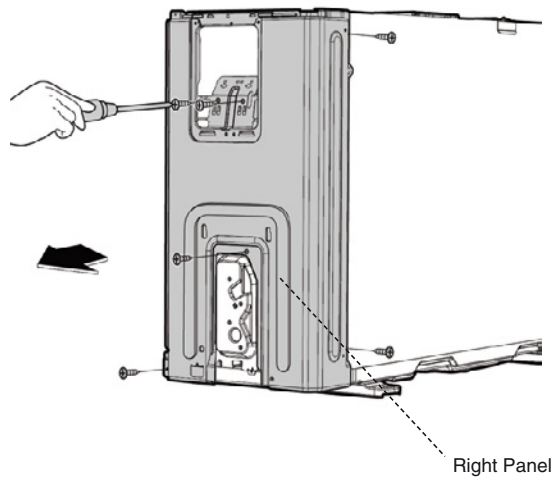

### Removing the PCB



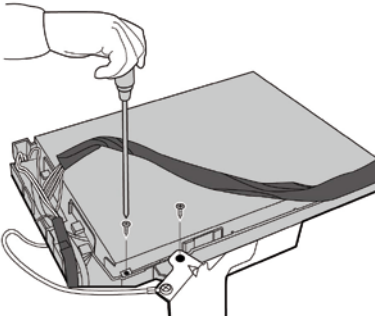
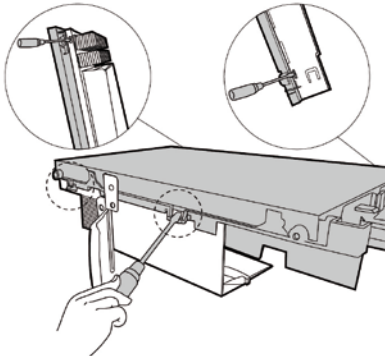
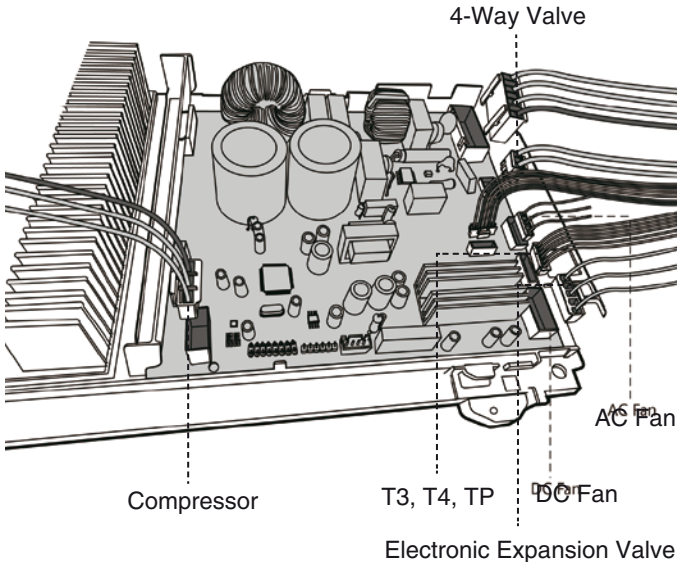

**WARNING:** Antistatic gloves must be worn when you disassemble the electronic box.

Note: Remove the air outlet grille before disassembling electrical parts.

Procedure	Illustration
<p>1) Remove the screws of the top cover (2 screws).</p>	
<p>2) Unfix the hooks and then open the electronic control box cover (4 hooks).</p>	
<p>3) Disconnect the connector for fan motor from the electronic control board.</p>	
<p>4) Remove the connector for the compressor.</p>	
<p>5) Pull out the two blue wires connected with the four way valve.</p>	
<p>6) Pull out connectors of the condenser coil temperature sensor (T3), outdoor ambient temperature sensor (T4) and discharge temperature sensor (TP).</p>	
<p>7) Disconnect the electronic expansion valve wire.</p>	
<p>8) Then remove the electronic control board.</p>	

### 7.2.3 Fan Assembly

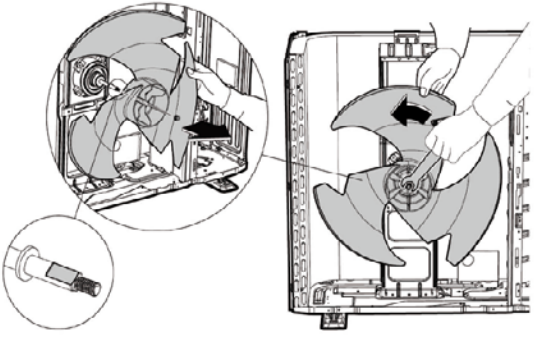
Note: Remove the panel plate before disassembling fan.

Procedure	Illustration
1) Remove the nut securing the fan with a spanner.	
2) Remove the fan.	

### 7.2.4 Fan Motor

Note: Remove the panel plate and the connection of fan motor on PCB before disassembling fan motor.

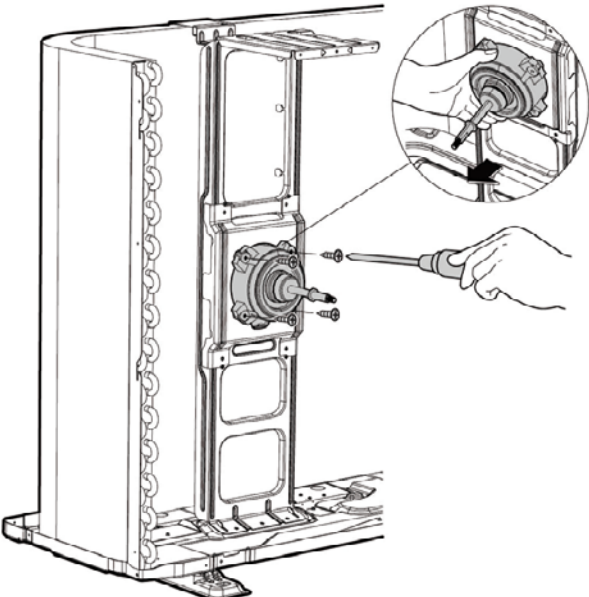
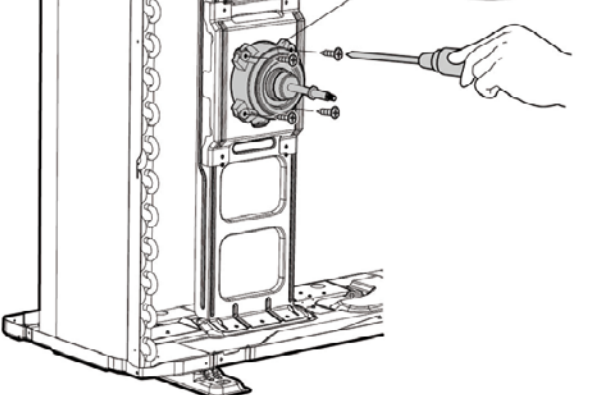
Procedure	Illustration
1) Remove the fixing screws of the fan motor (4 screws).	
2) Remove the fan motor.	

### 7.2.5 Sound blanket

Note: Remove the panel plate before disassembling sound blanket.

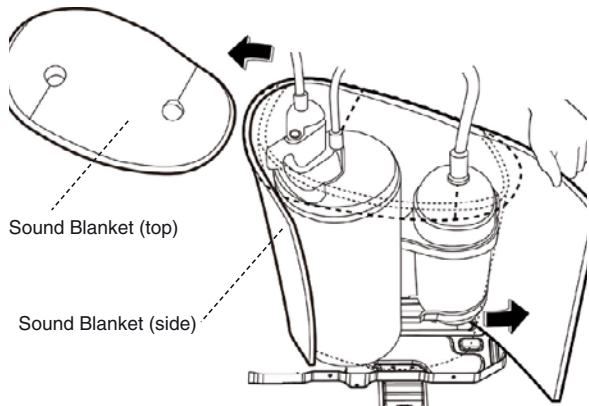
Procedure	Illustration
1) Remove the sound blanket (side and top).	

### 7.2.6 Four-way valve



**WARNING:** Evacuate the system and confirm that there is no refrigerant left in the system before removing the four-way valve and the compressor.

For R32, you should evacuate the system with the vacuum pump, then flush the system with nitrogen (OFN) and repeat the two steps before heating up the brazed parts. The operations above should be implemented by professionals.

Note: Remove the panel plate and the connection of fan motor on PCB before disassembling fan motor.

Procedure	Illustration
1) Heat up the brazed parts and then detach the the four-way valve and the pipe.	
2) Remove the four-way valve assembly with pliers.	

### 7.2.6 Compressor



**WARNING:** Evacuate the system and confirm that there is no refrigerant left in the system before removing the four-way valve and the compressor.

For R32, you should evacuate the system with the vacuum pump, then flush the system with nitrogen and repeat the two steps before heating up the brazed parts. The operations above should be implemented by professionals.

Note: Remove the panel plate and the connection of fan motor on PCB before disassembling fan motor.

Procedure	Illustration
1) Remove the sound blanket (side and top).	

2) Disconnect the connectors.

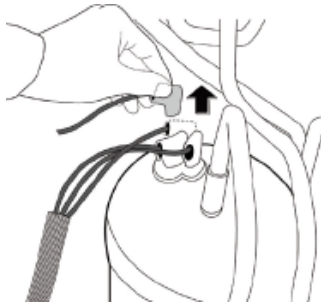

3) Remove the hex nuts and washers securing the compressor, located on the bottom plate.

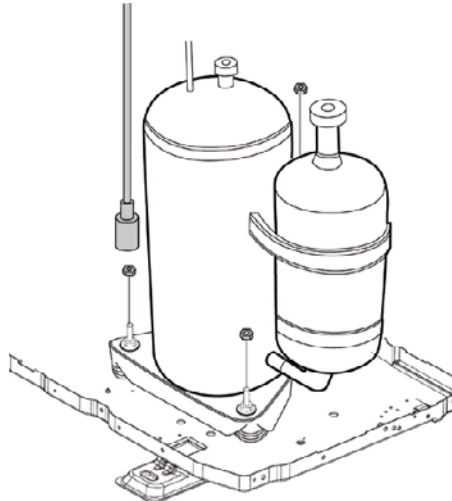

4) Heat up the brazed parts and then remove the discharge pipe and the suction pipe.

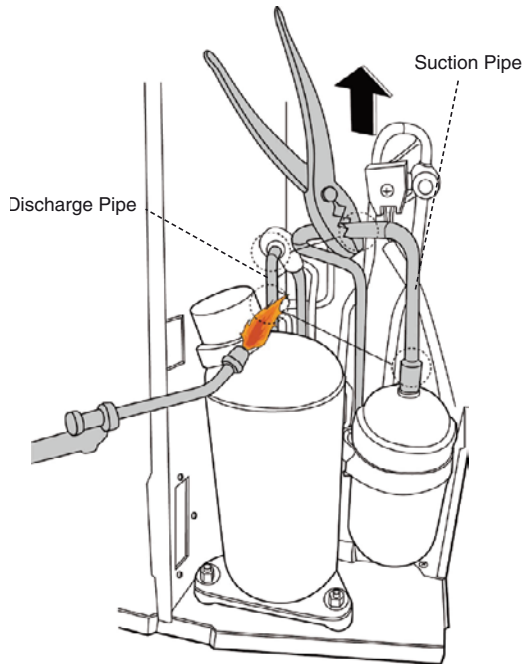

5) Lift the compressor from the base pan assembly with pliers.

# 8.0 Troubleshooting

## 8.1 Safety caution

**WARNING**

Be sure to turn off all power supplies or disconnect all wires to avoid electric shock. While checking indoor/outdoor PCB, please equip yourself with antistatic gloves or wrist strap to avoid damage to the board.

**WARNING**

Electricity remains in capacitors even when the power supply is off. Ensure the capacitors are fully discharged before troubleshooting.

Test the voltage between P and N on back of the main PCB with multimeter. If the voltage is 36V, the capacitors are fully discharged.

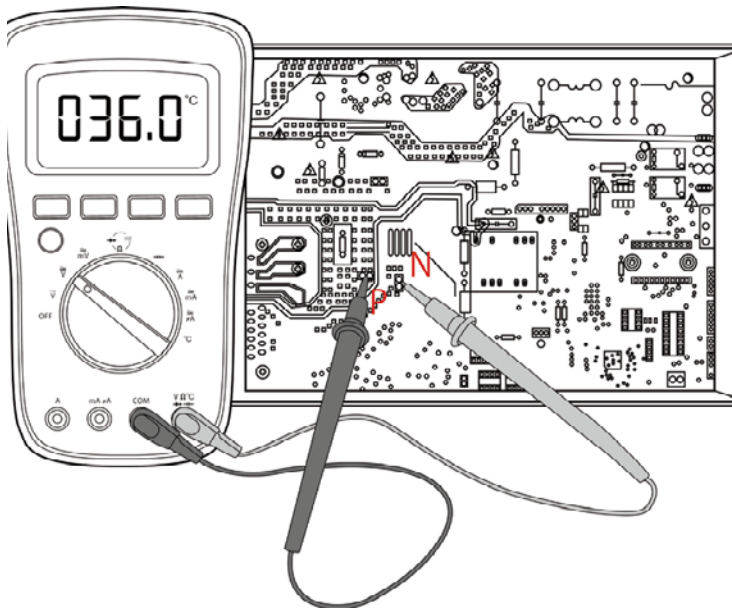

Note: This picture is for reference only. Actual appearance may vary.

## 8.2 General troubleshooting

### 8.2.1 Error Display (Indoor Unit)

When the Indoor Unit encounters a recognized error, the Operation Lamp will flash in a corresponding series, the Timer Lamp may turn ON or begin flashing, and an error code will be displayed. These error codes are described in the following table:

Operation Lamp	Timer Lamp	Display	Error information
1 time	OFF	E0	Indoor unit EEPROM parameter error.
2 times	OFF	E1	Indoor / outdoor unit communication error.
3 times	OFF	E2	Zero-crossing signal detection error (for some models).
4 times	OFF	E3	The indoor fan speed is operating outside of the normal range.
5 times	OFF	E4	Indoor room temperature sensor T1 is in open circuit or has short circuit.
6 times	OFF	E5	Evaporator coil temperature sensor T2 is in open circuit or has short circuit.
9 times	OFF	E7	Indoor PCB / Display board communication error (for some models).
7 times	OFF	EC	Refrigerant leak detected.
1 time	ON	F0	Current overload protection.
2 times	ON	F1	Outdoor temperature sensor T4 is in open circuit or has short circuit.

3 times	ON	<i>F2</i>	Condenser coil temperature sensor T3 is in open circuit or has short circuit.
4 times	ON	<i>F3</i>	Compressor discharge temperature sensor TP is in open circuit or has short circuit.
5 times	ON	<i>F4</i>	Outdoor unit EEPROM parameter error.
6 times	ON	<i>F5</i>	The outdoor fan speed is operating outside of the normal range (for some models).
1 time	FLASH	<i>P0</i>	IPM malfunction or IGBT over-strong current protection.
2 times	FLASH	<i>P1</i>	Over voltage or too low voltage protection.
3 times	FLASH	<i>P2</i>	High temperature protection of IPM module.
5 times	FLASH	<i>P4</i>	Inverter compressor drive error.
7 times	FLASH	<i>P6</i>	Low pressure protection (for some models).

- For other errors:  
The display board may show a garbled code or a code undefined by the Service Manual. Ensure that this code is not a temperature reading.
- Troubleshooting:  
Test the unit using the remote control. If the unit does not respond to the remote, the indoor PCB requires replacement. If the unit responds, the display board requires replacement.

### For some models

When the Indoor Unit encounters a recognized error, the Operation Lamp will flash in a corresponding series, the Timer Lamp may turn ON or begin flashing, and an error code will be displayed. These error codes are described in the following table:

Operation Lamp	Timer Lamp	Display	Error information
1 time	OFF	<i>EH 00</i>	Indoor unit EEPROM parameter error.
2 times	OFF	<i>EL 01</i>	Indoor / outdoor unit communication error.
3 times	OFF	<i>EH 02</i>	Zero-crossing signal detection error (for some models).
4 times	OFF	<i>EH 03</i>	The indoor fan speed is operating outside of the normal range.
5 times	OFF	<i>EC 51</i>	Outdoor unit EEPROM parameter error (for some models).
5 times	OFF	<i>EC 52</i>	Condenser coil temperature sensor T3 is in open circuit or has short circuit.
5 times	OFF	<i>EC 53</i>	Outdoor temperature sensor T4 is in open circuit or has short circuit.
5 times	OFF	<i>EC 54</i>	Compressor discharge temperature sensor TP is in open circuit or has short circuit.
6 times	OFF	<i>EH 60</i>	Indoor room temperature sensor T1 is in open circuit or has short circuit.
6 times	OFF	<i>EH 61</i>	Evaporator coil temperature sensor T2 is in open circuit or has short circuit.
12 times	OFF	<i>EC 07</i>	The outdoor fan speed is operating outside of the normal range (for some models).
9 times	OFF	<i>EC 08</i>	Indoor PCB / Display board communication error (for some models).
8 times	OFF	<i>EL 0C</i>	Refrigerant leak detected.
7 times	FLASH	<i>PC 00</i>	IPM malfunction or IGBT over-strong current protection.
2 times	FLASH	<i>PC 01</i>	Over voltage or too low voltage protection.
3 times	FLASH	<i>PC 02</i>	High temperature protection of IPM module or High pressure protection.
5 times	FLASH	<i>PC 04</i>	Inverter compressor drive error.
1 time	FLASH	<i>PC 08</i>	Current overload protection (for some models).
7 times	FLASH	<i>PC 03</i>	Low pressure protection (for some models).

LED flash frequency:



### 8.2.2 Error Display (for HCNI 533 Outdoor Unit)

There are 2 LED lights (Red color and Green color) welded in outdoor main board. After power on, LED show different actions when encounter different problems.

No.	Problem	LED (Green)	LED (Red)
1	Standby normally.	ON	OFF
2	Operate normally.	OFF	ON
3	Compressor driven chip EEPROM parameter error.	ON	FLASH
4	IPM malfunction or IGBT over-strong current protection.	FLASH	OFF
5	Over voltage or too low voltage protection.	ON	ON
6	Inverter compressor drive error.	OFF	FLASH
7	Inverter compressor drive error.	FLASH	LIGHT
8	Communication error between outdoor main chip and compressor driven chip.	FLASH	FLASH

### 8.3 Information inquiry

- To enter information inquiry status, complete the following procedure within 10 seconds:
  - Press 3 times LED button on the IR Remote Control.
  - Press 3 times SWING button on the IR Remote Control.
- Finish 1 and 2 within 10 seconds; you will hear beeps for 2 seconds, which means the unit goes into parameter checking mode.
- Use the LED and SWING buttons to cycle through information displayed.
  - Pressing LED button will display the next code in the sequence.
  - Pressing SWING button will show the previous code in the sequence.
- The following table (see on next page) shows information codes. The screen will display this code for 2 seconds, then the relevant information for 25 seconds.

Displayed Code	Explanation	Displayed value	Meaning	Additional Notes
T1	Room temp.	- 1F,-1E,-1d,-1c,-1b,-1A - 19—99 A0,A1,...A9 b0,b1,...b9 c0,c1,...c9 d0,d1,...d9 E0,E1,...E9 F0,F1,...F9	- 25,-24,-23,-22, -21,-20 - 19—99 100,101,...109 110,111,...119 120,121,...129 130,131,...139 140,141,...149 150,151,...159	1. All displayed temperatures use actual values. 2. All temperatures are displayed in °C regardless of remote used. 3. T1, T2, T3, T4, and T2B display ranges from -25°C to 70°C. TP display ranges from -20°C to 130 °C. 4. The frequency display ranges from 0 to 159Hz. 5. If the actual values exceed or fall short of the defined range, the values closest to the maximum and minimum values will be displayed.
T2	Indoor coil temp.			
T3	Outdoor coil temp.			
T4	Ambient temp.			
TB	Outlet temp. of indoor coil.			
TP	Discharge temp.			
TH	Suction temp.			
FT	Targeted frequency.			
FR	Actual frequency.			
IF	Indoor fan speed.	0 1,2,3,4	OFF Low speed, Medium speed, High speed, Turbo.	N/A Used for some large capacity motors.
OF	Outdoor fan speed.	14-FF	Actual fan speed is equal to the display value converted to decimal value and multiplied by 10. This is measured in RPM.	Used for some small capacity motors. The display value is 14-FF (hexadecimal). Corresponding fan speed ranges from 200 RPM to 2550RPM.
LA	EXV opening angle.	0-FF	Actual EXV opening value is equal to the display value converted to decimal value and then multiplied by 2.	-



CT	Compressor continuous running time.	0-FF	0-255 minutes.	If the actual value exceeds or falls short of the defined range, the value closest to the maximum and minimum will be displayed.
ST	Causes of compressor stop.	0-99	For a detailed explanation, contact technical support.	-
A0	Reserved	0-FF 2-28 5-20 5-25	-	-
A1				
0				
1				
2				
3				
4				
5				
6				
L				
A				
U				
T				
A				
5				
T				

#### 8.4 Error diagnosis and troubleshooting without error code



#### WARNING

Be sure to turn off unit before any maintenance to prevent damage or injury.

##### 8.4.1 Remote maintenance

SUGGESTION: When troubles occur, please check the following points with customers before field maintenance.

No.	Problem
1	Unit will not start
2	The power switch is on but fans will not start
3	The temperature on the display board cannot be set
4	Unit is on, but the wind is not cold (hot)
5	Unit runs, but it shortly stops
6	The unit starts up and stops frequently
7	Unit runs continuously but with insufficient cooling (heating) effect
8	Cooling mode cannot be changed to heating mode
9	Unit is noisy

1. Remote maintenance	Electrical Circuit						Refrigerant Circuit							
Possible causes of trouble	Power failure	The main power tripped	Loose connections	Faulty transformer	The voltage is too high or too low	The remote control is powered off	Broken remote control	Dirty air filter	Dirty condenser fins	The seng temperature is higher/lower than the room's (cooling/heang)	The ambient temperature is too high/low when the mode is cooling/heang	Fan mode	SILENCE funcon is acvated (oponal funcon)	Frosng and defrosng frequently
Unit will not start	■	■	■	■	■									
The power switch is on but fans will not start			■	■	■									
The temperature on the display board cannot be set						■	■							
Unit is on but the wind is not cold (hot)										■	■	■		
Unit runs, but shortly stops					■					■	■	■		
The unit starts up and stops frequently					■					■	■	■		■
Unit runs connuously but insufficient cooling (heang)								■	■	■	■	■	■	■
Cool can not change to heat														
Unit is noisy														
Test method / remedy	Test voltage	Close the power switch	Inspect connectons - tighten	Change the transformer	Test voltage	Replace the battery of the remote control	Replace the remote control	Clean or replace	Clean	Adjust the seng temperature	Turn the AC later	Adjust to cool mode	Turn off SILENCE funcon.	Turn the AC later

1. Remote maintenance	Others					
Possible causes of trouble	Heavy load condition	Loosen hold down bolts and / or screws	Bad airproof	he air inlet or outlet of either unit is blocked	Interference from cell phone towers and remote boosters	Shipping plates remain attached
Unit will not start						
The power switch is on but fans will not start						
The temperature on the display board cannot be set						
Unit is on but the wind is not cold (hot)						
Unit runs, but shortly stops						
The unit starts up and stops frequently						
Unit runs continuously but insufficient cooling (heang)						
Cool can not change to heat						
Unit is noisy						
Test method / remedy	Check heat load	Tighten bolts or screws	Close all the windows and doors	Remove the obstacles	Reconnect the power or press ON/OFF button on remote control to restart operation	Remove them

#### 8.4.2 Field maintenance

No.	Problem
1	Unit will not start
2	Compressor will not start, but fans run.
3	Compressor and condenser (outdoor) fan will not start.
4	Evaporator (indoor) fan will not start.
5	Condenser (Outdoor) fan will not start.
6	Unit runs, but it shortly stops.
7	Compressor short-cycles due to overload.
8	High discharge pressure.
9	Low discharge pressure.
10	High suction pressure.
11	Low suction pressure.
12	Unit runs continuously but with insufficient cooling effect.
13	Too much cooling effect.
14	Compressor is noisy.
15	Horizontal louver can not revolve.

1. Field Maintenance	Electrical Circuit														
Possible causes of trouble	Power failure	Blown fuse or varistor	Loose connections	Shorted or broken wires	Safety device opens	Faulty thermostat / room temperature sensor	Wrong sensing place of temperature sensor	Faulty transformer	Shorted or open capacitor	Faulty magnetic contactor for compressor	Faulty magnetic contactor for fan	Low voltage	Faulty stepping motor	Shorted or grounded compressor	Shorted or grounded fan motor
Unit will not start															
Compressor will not start but fans run															
Compressor and condenser (outdoor) fan will not start															
Evaporator (indoor) fan will not start															
Condenser (Outdoor) fan will not start															
Unit runs, but shortly stops															
Compressor short-cycles due to overload															
High discharge pressure															
Low discharge pressure															
High suction pressure															
Low suction pressure															
Unit runs continuously but insufficient cooling															
Too cool															
Compressor is noisy															
Horizontal louver can not revolve															
Test method / remedy	Test voltage	Inspect fuse type & size	Inspect connections - tighten	Test circuits with tester	Test continuity of safety device	Test continuity of thermostat / sensor & wiring	Place the temperature sensor at the center of the air inlet grille	Check control circuit with tester	Check capacitor with tester	Test continuity of coil & contacts	Test continuity of coil & contacts	Test voltage	Replace the stepping motor	Check resistance with multimeter	Check resistance with multimeter

Refrigerant Circuit													Others	
Replace the compressor													Compressor stuck	
Leak test													Shortage of refrigerant	
Replace restricted part													Restricted liquid line	
Clean or replace													Dirty air filter	
Clean coil													Dirty evaporator coil	
Check fan													Insufficient air through evaporator coil	
Change charged refrigerant volume													Overcharge of refrigerant	
Clean condenser or remove obstacle													Dirty or parally blocked condenser	
Purge, evacuate and recharge													Air or incompressible gas in refrigerant cycle	
Remove obstrucon to air flow													Short cycling of condensing air	
Remove obstrucon in air or water flow													High temperature condensing medium	
Remove obstrucon in air or water flow													Insufficient condensing medium	
Replace compressor													Broken compressor internal parts	
Test compressor efficiency													Inefficient compressor	
Replace valve													Expansion valve obstructed	
Replace valve													Expansion valve or capillary tube closed completely	
Replace valve													Leaking power element on expansion valve	
Fix feeler bulb													Poor installaon of feeler bulb	
Check heat load													Heavy load condion	
Tighten bolts or screws													Loosen hold down bolts and / or screws	
Remove them													Shipping plates remain aached	
Choose AC of lager capacity or add the number of AC													Poor choices of capacity	
Rectfy piping so as not to contact each other or with external plate													Contact of piping with other piping or external plate	

### 8.5 Quick maintenance by error code

If you do not have the time to test whether specific parts are faulty, you can directly change the required parts according to the error code. You can find the parts to replace by error code in the following table.

Part requiring replacement	Error code								
	E0	E1	E2	E4	E4	E5	E7/Eb	EC	F0
	EH 00	EL 01	EH 02	EH 03	EH 60	EH 61	EH 0B	EL 0C	PC 08
Indoor PCB	✓	✓	✓	✓	✓	✓	✓	✓	x
Outdoor PCB	x	✓	x	x	x	x	x	x	✓
Display board	x	x	x	x	x	x	✓	x	x
Indoor fan motor	x	x	x	✓	x	x	x	x	x
T1 sensor	x	x	x	x	✓	x	x	x	x
T2 Sensor	x	x	x	x	x	✓	x	✓	x
Reactor	x	✓	x	x	x	x	x	x	x
Compressor	x	x	x	x	x	x	x	x	✓
Additional refrigerant	x	x	x	x	x	x	x	✓	x

Part requiring replacement	Error code									
	F1	F2	F3	F4	F5	P0	P1	P2	P6	P4
	EC 53	EC 52	EC 54	EC 51	EC 07	PC 00	PC 01	PC 02	PC 03	PC 04
Indoor PCB	x	x	x	x	x	x	x	x	x	x
Outdoor PCB	✓	✓	✓	✓	✓	✓	✓	✓	✓	✓
Indoor fan motor	x	x	x	x	x	x	x	x	x	x
Outdoor fan motor	x	x	x	x	✓	✓	x	✓	x	✓
T3 Sensor	x	✓	x	x	x	x	x	x	x	x
T4 Sensor	✓	x	x	x	x	x	x	x	x	x
TP Sensor	x	x	✓	x	x	x	x	x	x	x
Reactor	x	x	x	x	x	x	✓	x	x	x
Compressor	x	x	x	x	x	✓	x	x	x	✓
IPM module board	x	x	x	x	x	✓	✓	✓	✓	x
High pressure protector	x	x	x	x	x	x	x	✓	x	x
Low pressure protector	x	x	x	x	x	x	x	x	✓	x
Additional refrigerant	x	x	x	x	x	x	x	x	✓	x

Note: For certain models, outdoor PCB could not be removed separately. In this case, the outdoor electric control box should be replaced as a whole.

## 8.5 Troubleshooting by error code

### 8.5.1 E0 / EH 00 / F4 / EC 51 (EEPROM parameter error diagnosis and solution)

**Description:** Indoor or outdoor PCB main chip does not receive feedback from EEPROM chip.

#### Recommended parts to prepare:

- Indoor PCB
- Outdoor PCB

#### Troubleshooting and repair:

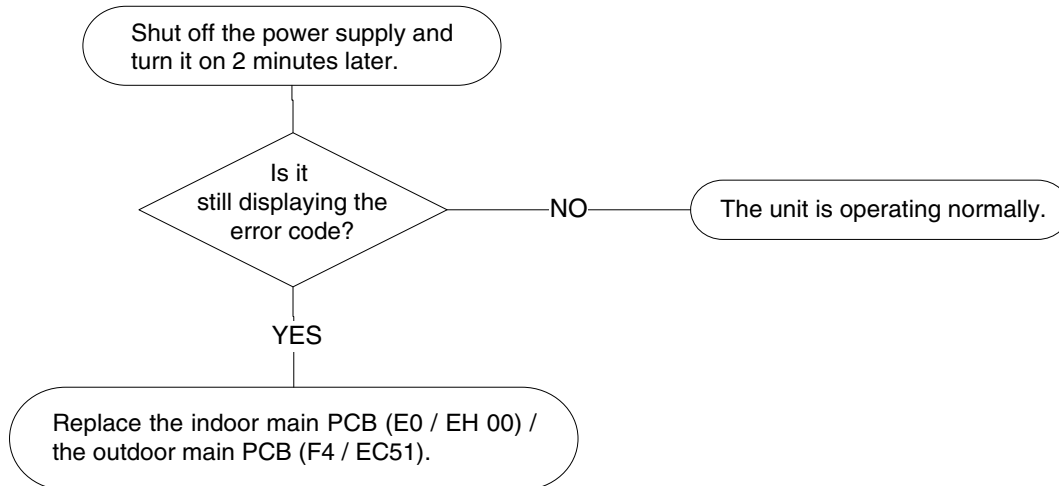

#### Remarks:

EEPROM is a read-only memory whose contents can be erased and reprogrammed using a pulsed voltage. The location of the EEPROM chip on the indoor and outdoor PCB is shown in the following two images:

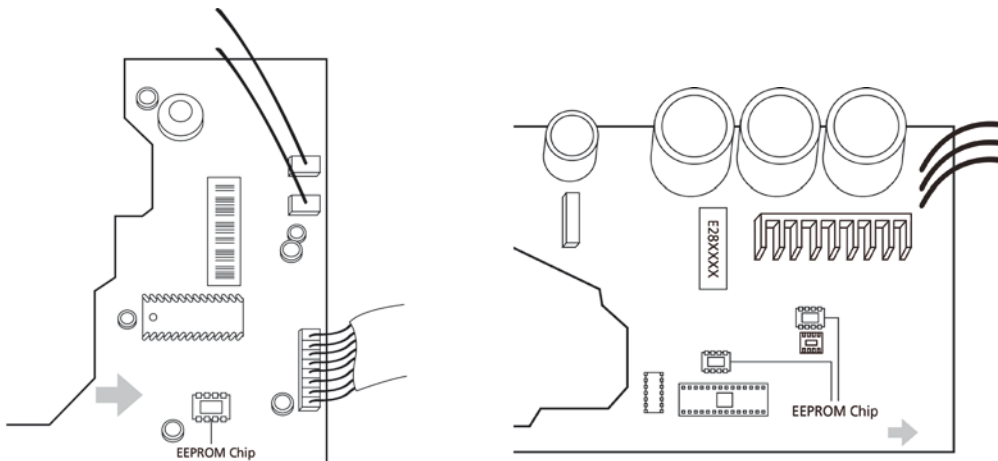

#### Notes:

For certain models, outdoor PCB could not be removed separately. In this case, the outdoor electric control box should be replaced as a whole. These pictures are only for reference, actual appearance may vary.

Troubleshooting and repair of compressor driven chip EEPROM parameter error and communication error between outdoor main chip and compressor driven chip are same as F4 / EC 51.

8.5.2 E1 / EL 01 (Indoor and Outdoor Unit communication error diagnosis and solution)

**Description:** Indoor Unit can not communicate with Outdoor Unit.

**Recommended parts to prepare:**

- Indoor PCB
- Outdoor PCB
- Short-circuited component

**Troubleshooting and repair:**

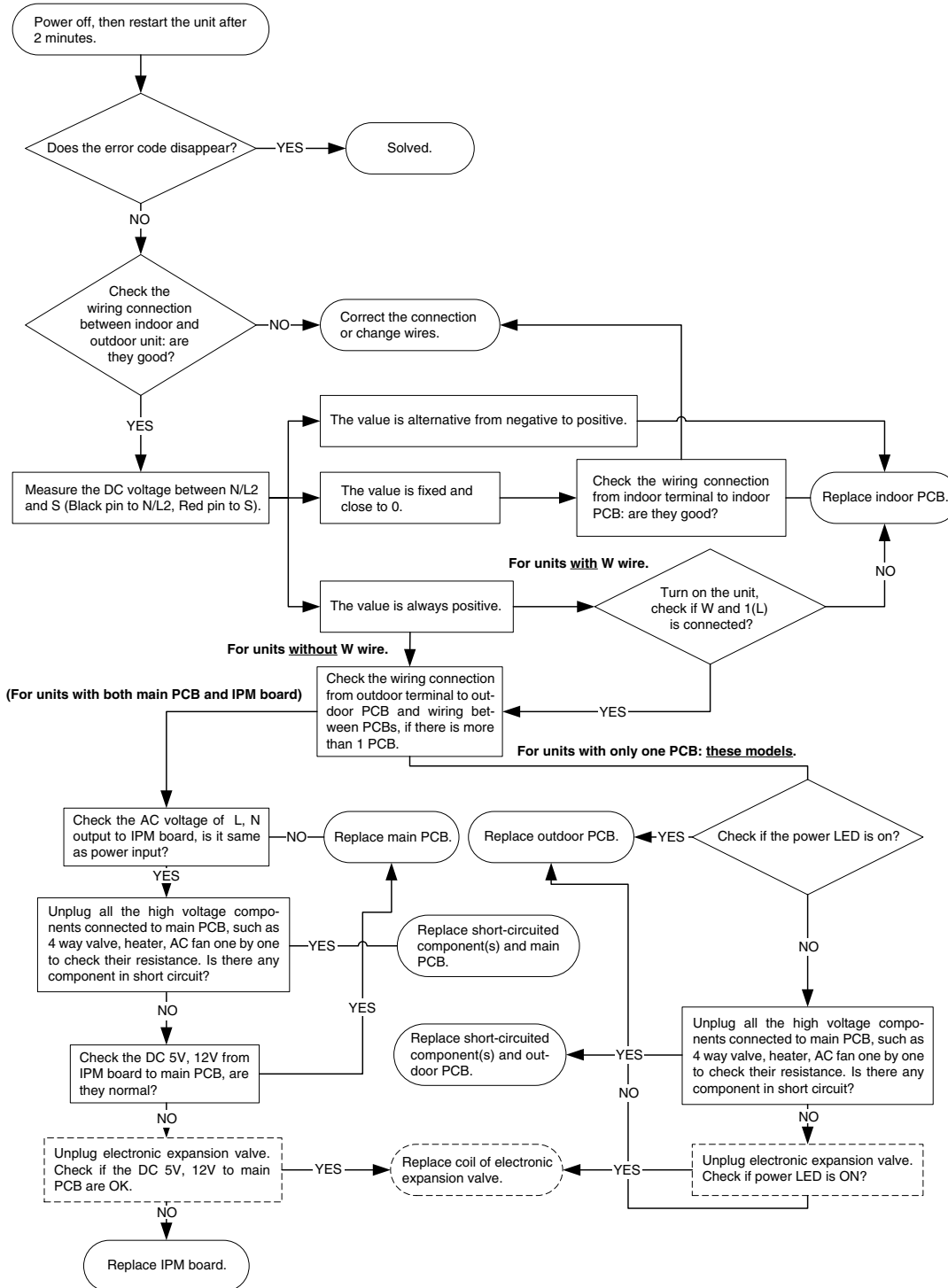

**Notes:**

For certain models, outdoor PCB could not be removed separately. In this case, the outdoor electric control box should be replaced as a whole.



**Remarks:**

- Use a multimeter to test the DC voltage between 2 port (or S or L2 port) and 3 port (or N or S port) of outdoor unit.
- The Red pin of multimeter connects with 2 port (or S or L2 port), while the Black pin is for 3 port (or N or S port).
- When AC is normally running, the voltage is moving alternately as positive and negative values.
  - If the outdoor unit has malfunction, the voltage will move alternately with positive values.
  - While if the indoor unit has malfunction, the voltage will be a certain value.

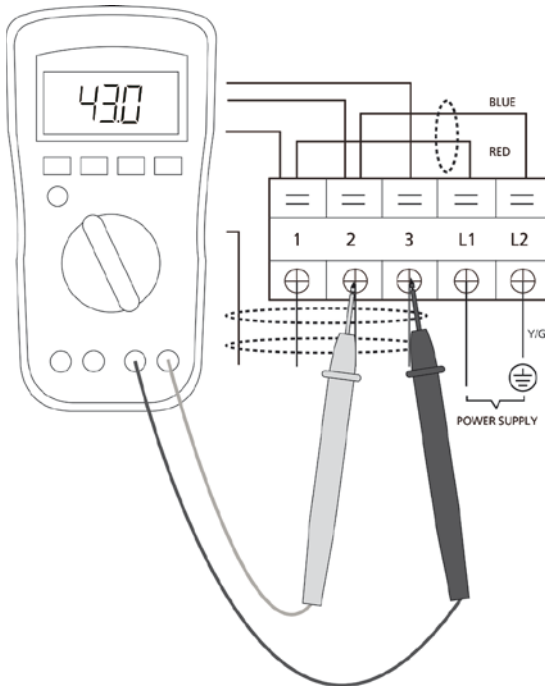

S and N, or L2 and S, or 2 and 3.

- Use a multimeter to test the resistance of the reactor which does not connect with capacitor.
- The normal value should be around 0 . Otherwise, the reactor must have malfunction.

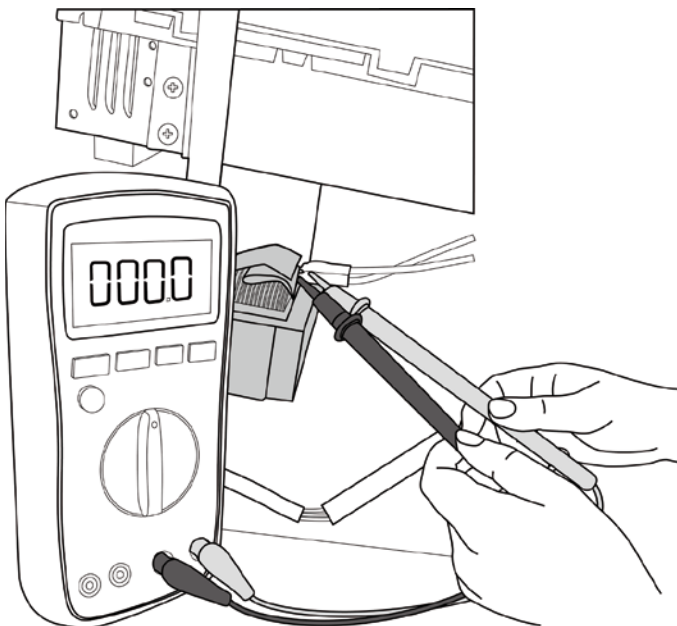

Note: The picture and the value are only for reference, actual condition and specific value may vary.

### 8.5.3 E2 / EH 02 (Zero crossing detection error diagnosis and solution)

**Description:** When PCB does not receive zero crossing signal feedback for 4 minutes or the zero crossing signal time interval is abnormal.

**Recommended parts to check or to prepare:**

- Connection wires
- PCB

**Troubleshooting and repair:**

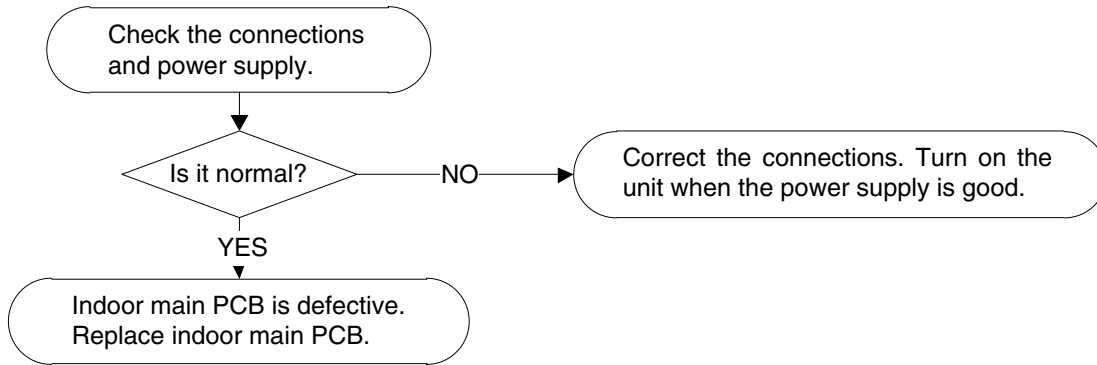

**Note:**

**E2 / EH 02 zero crossing detection error is only valid for the unit with AC fan motor, for other models, this error is invalid.**

## 8.5.4 E3 / EH 03 / F5 / EC 07 (Fan speed is operating outside of the normal range diagnosis and solution)

**Description:** When the indoor / outdoor fan speed keeps too low or too high for a certain time, the LED displays the failure code and the AC turns off.

### Recommended parts to check or to prepare:

- Connection wires
- Fan assembly
- Fan motor
- PCBs

### Troubleshooting and repair:

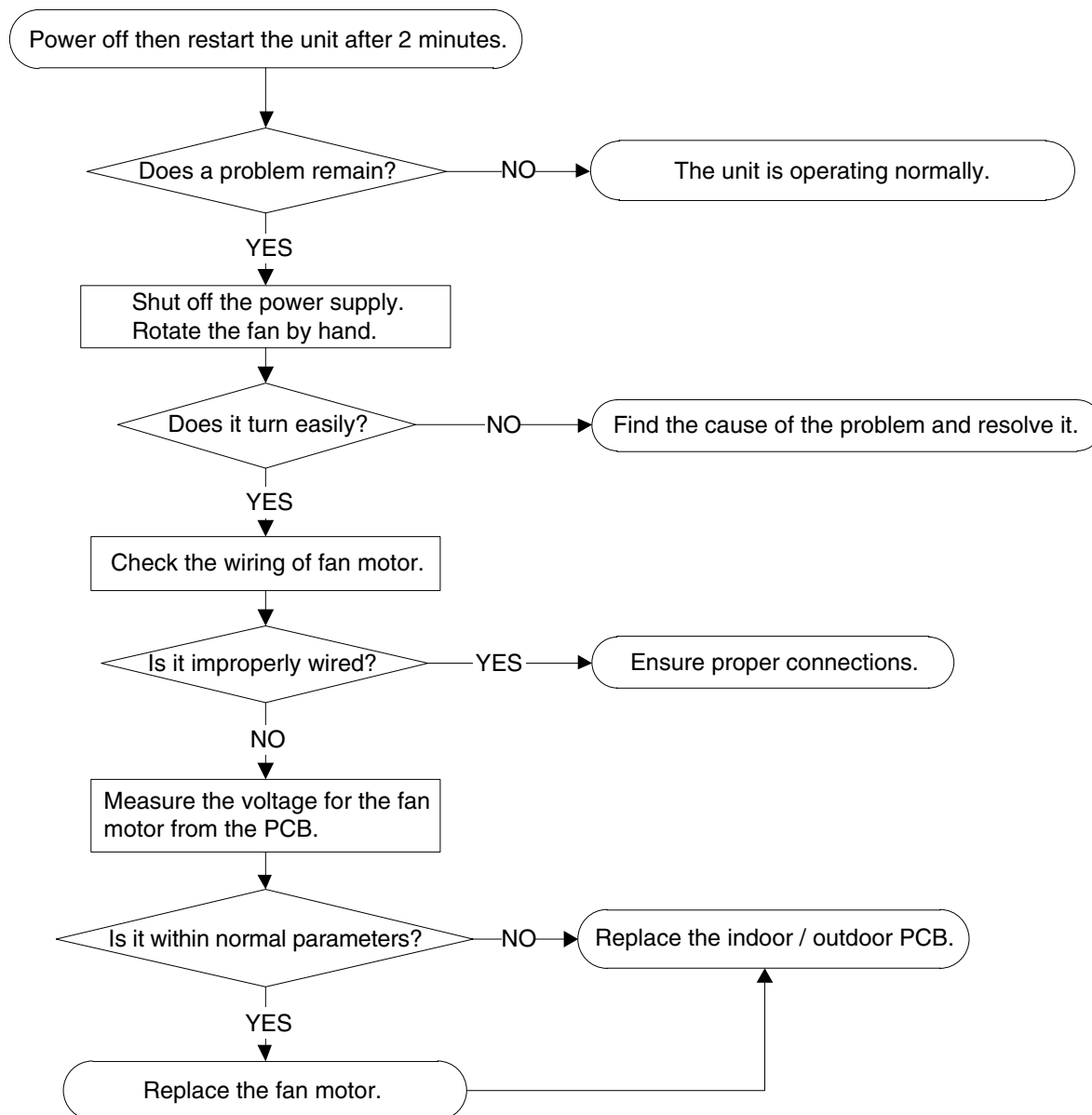

### Note:

For certain models, outdoor PCB could not be removed separately. In this case, the outdoor electric control box should be replaced as a whole

**Index:**

**1. Indoor or Outdoor DC Fan Motor (control chip is in fan motor)**

Power on and when the unit is in standby, measure the voltage of pin1-pin3, pin4-pin3 in fan motor connector. If the value of the voltage is not in the range shown in below table, the PCB must have problems and needs to be replaced.

• **DC motor voltage input and output (voltage: 220-240V AC):**

No.	Color	Signal	Voltage
1	Red	Vs/Vm	280V~380V
2	---	---	---
3	Black	GND	0V
4	White	Vcc	14-17.5V
5	Yellow	Vsp	0~5.6V
6	Blue	FG	14-17.5V

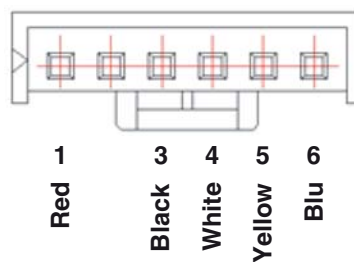

**2. Outdoor DC Fan Motor (control chip is in outdoor PCB)**

Release the UVW connector. Measure the resistance of U-V, U-W, V-W.

If the resistance values are not equal to each other, the fan motor must have problems and need to be replaced; otherwise the PCB must have problems and need to be replaced.

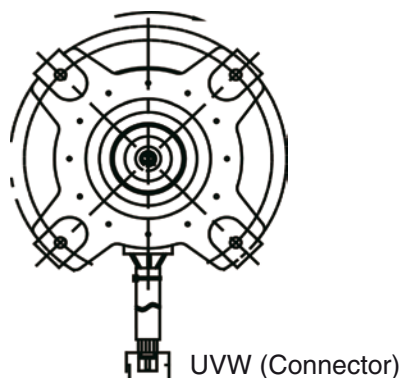

### 3. Indoor AC Fan Motor

Power on and set the unit running in fan mode at high fan speed.

After running for 15 seconds, measure the voltage of pin1 and pin2. If the value of the voltage is less than 100V (208~240V power supply), the PCB must have problems and needs to be replaced.

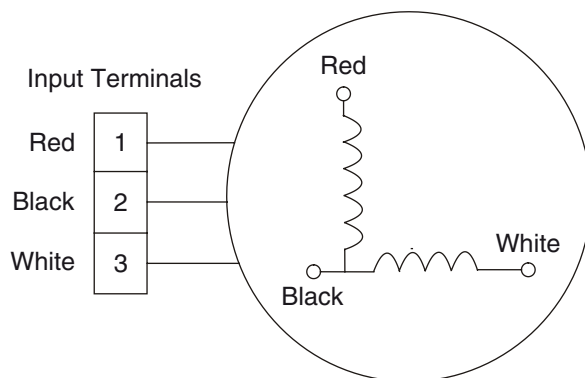

### 8.5.5 E4 / EH 60 / E5 / EH 61 / F1 / EC 53 / F2 / EC 52 / F3 / EC 54 (Open circuit or short circuit of temperature sensor diagnosis and solution)

**Description:** If the sampling voltage is lower than 0.06V or higher than 4.94V, the LED displays the failure code.

#### Recommended parts to check or to prepare:

- Connection wires
- Sensors
- PCB

#### Troubleshooting and repair:

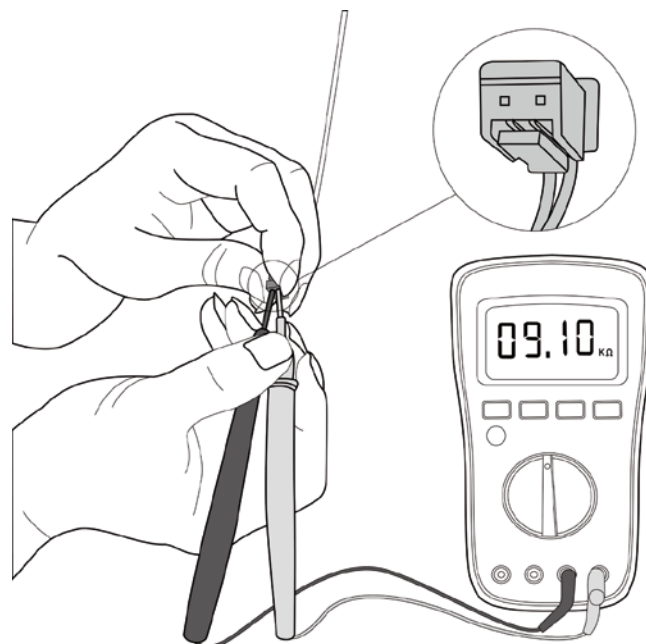
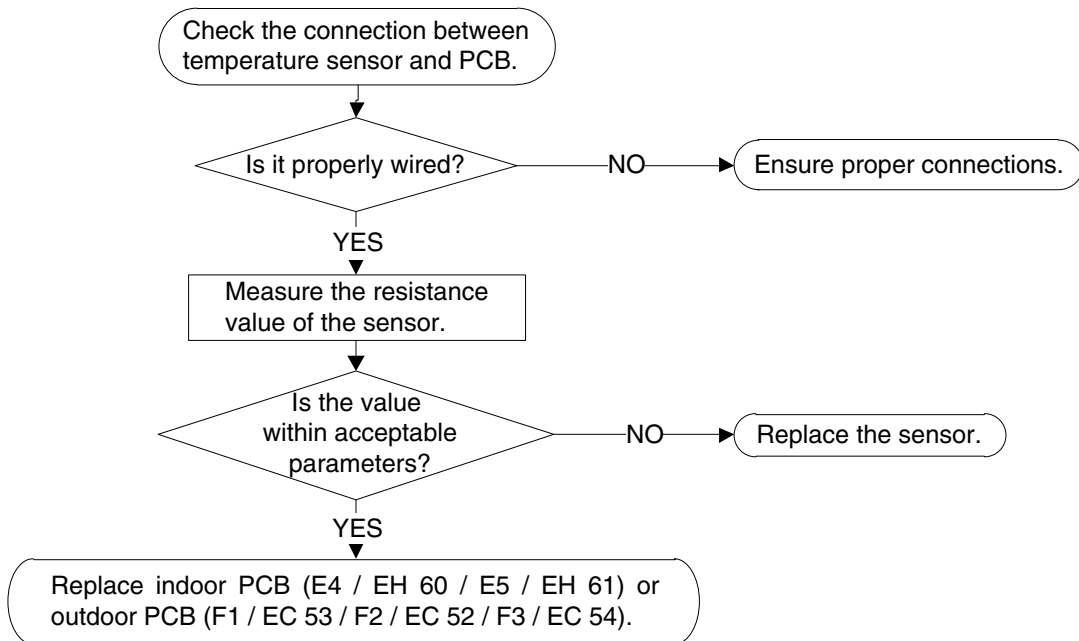

#### Note:

For certain models, outdoor PCB could not be removed separately. In this case, the outdoor electric control box should be replaced as a whole. This picture and the value are only for reference, actual appearance and value may vary. For certain models, outdoor unit uses combination sensor, T3, T4 and TP are in the same group.

## 8.5.6 E7 / EH / 0b (Indoor PCB / Display board communication error diagnosis and solution)

**Description:** Indoor PCB does not receive feedback from the display board.

**Recommended parts to check or to prepare:**

- Communication wire
- Indoor PCB
- Display board

**Troubleshooting and repair:**

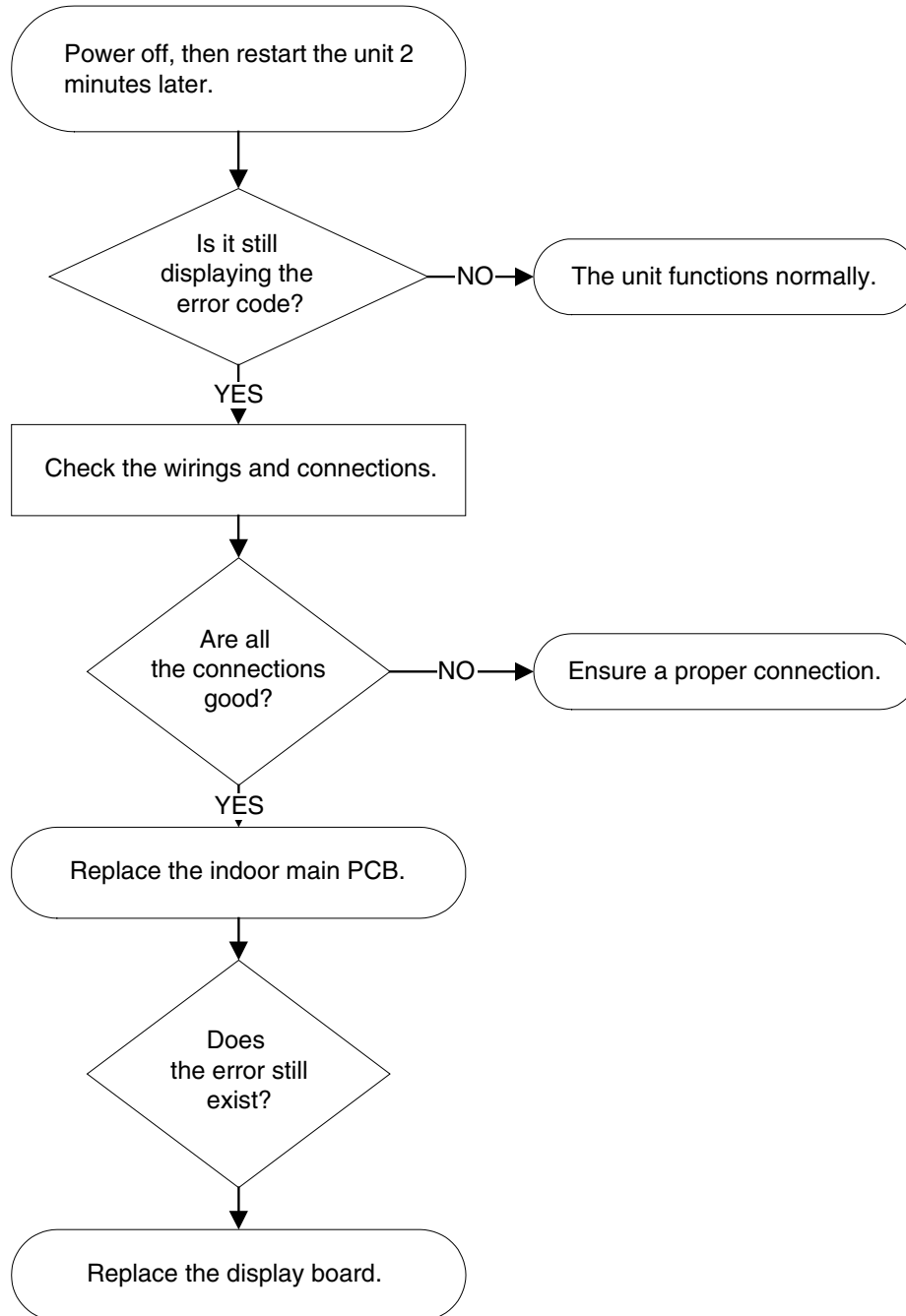

### 8.5.7 EC / EL 0C (Refrigerant Leakage Detection diagnosis and solution)

**Description:** Define the evaporator coil temp. T2 of the compressor when it just starts running, as “Tcool”. In the beginning 8 minutes after the compressor starts up, if  $T2 < (T_{cool} - 1)^{\circ}\text{C}$  does not keep for continuous 4 seconds and compressor running frequency higher than 50Hz does not keep for continuous 3 minutes, and this situation happens 3 times, the LED displays the failure code and the AC will turn off.

#### Recommended parts to prepare or to check:

- T2 sensor
- Indoor PCB
- Additional refrigerant

#### Troubleshooting and repair:

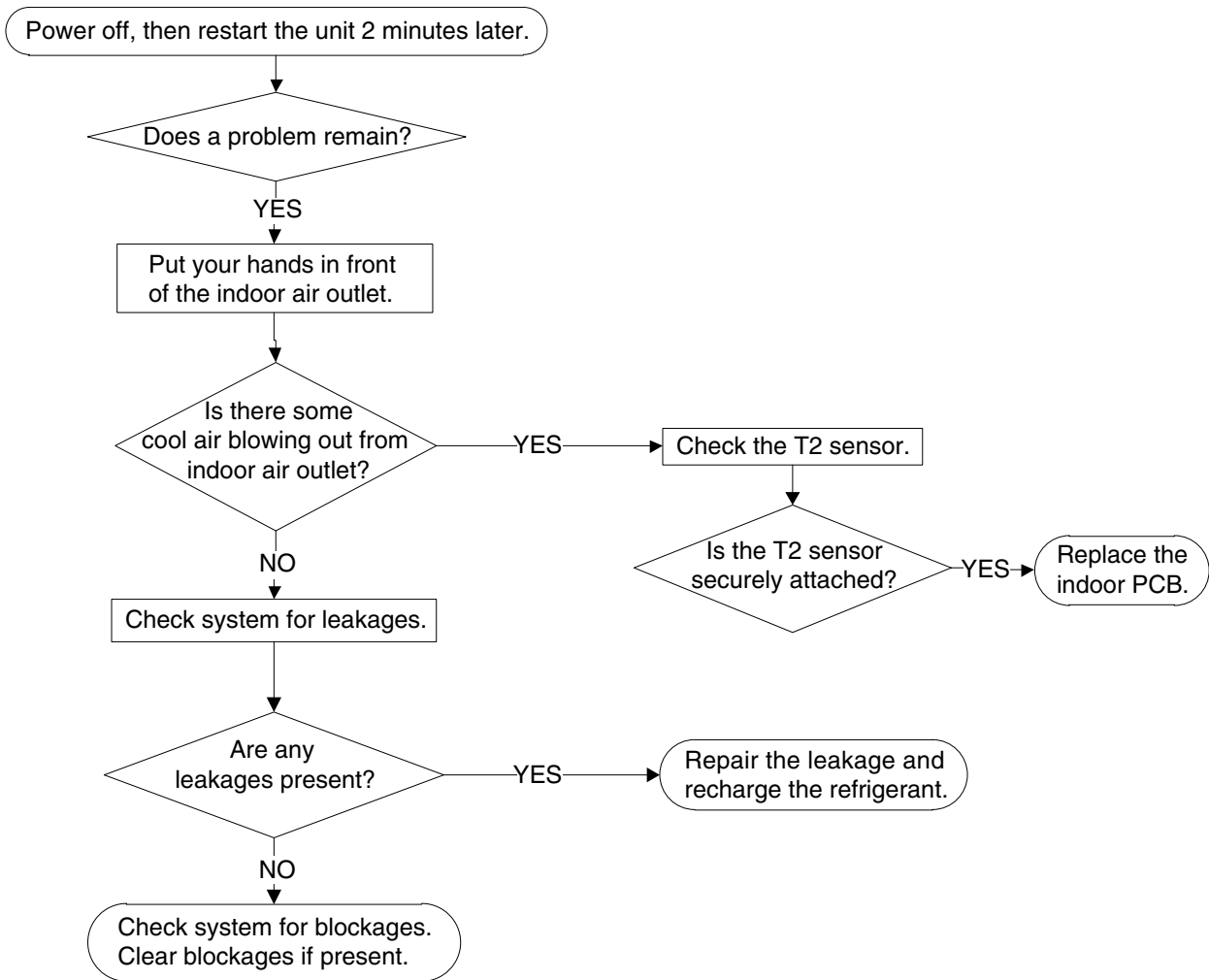



### 8.5.8 F0 / PC 08 (Overload current protection diagnosis and solution)

**Description:** An abnormal current rise is detected by checking the specified current detection circuit.

**Recommended parts to check or to prepare:**

- Outdoor PCB
- Connection wires
- Compressor

**Troubleshooting and repair:**

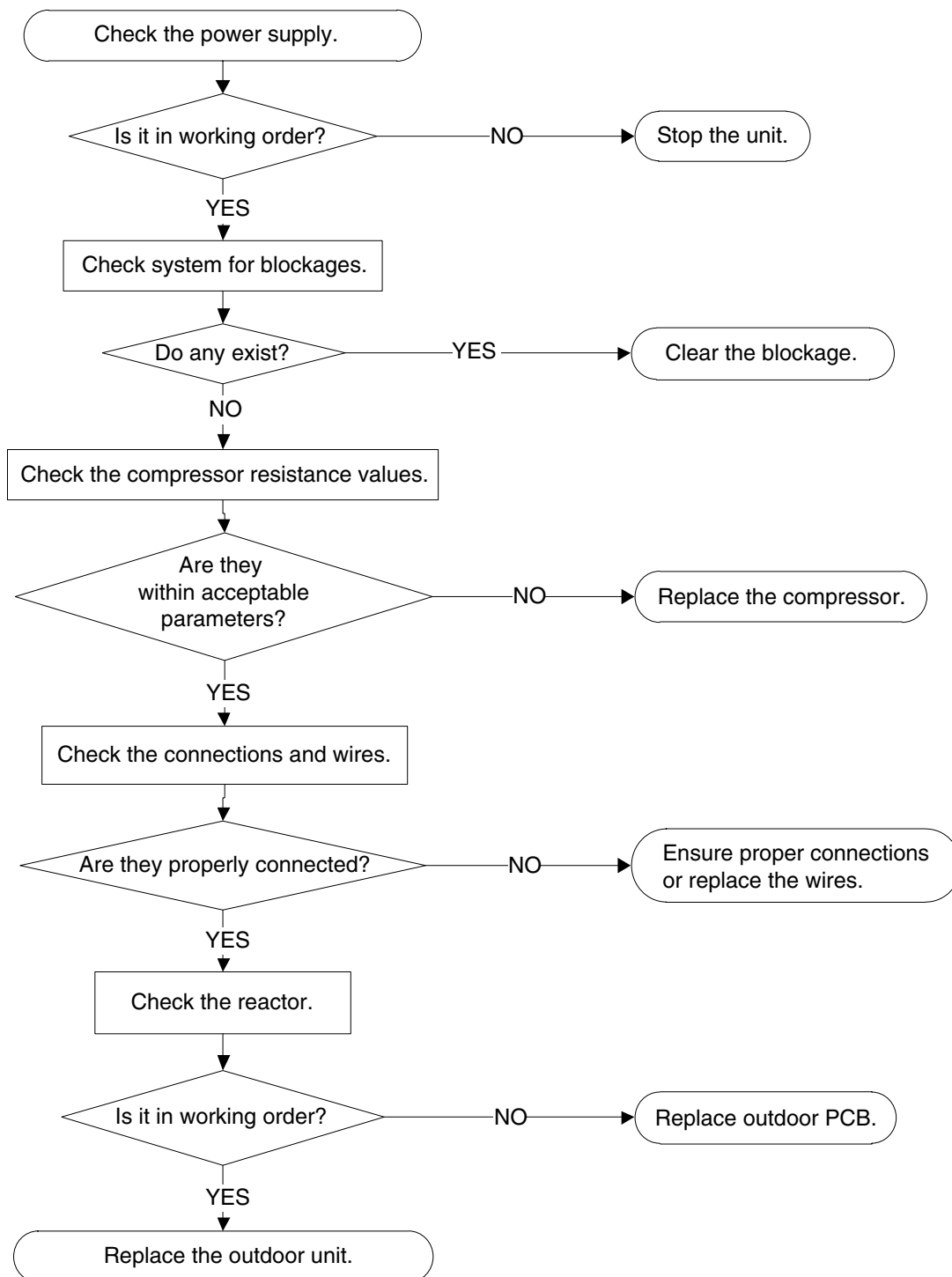

**Note:**

For certain models, outdoor PCB could not be removed separately. In this case, the outdoor electric control box should be replaced as a whole.

### 8.5.9 P0 / PC 00 (IPM malfunction or IGBT over-strong current protection diagnosis and solution)

**Description:** When the voltage signal which the IPM sends to the compressor drive chip is abnormal, the LED displays the failure code and the AC turns off.

#### Recommended parts to check or to prepare:

- Connection wires
- IPM module board
- Outdoor fan assembly
- Compressor
- Outdoor PCB

#### Troubleshooting and repair:

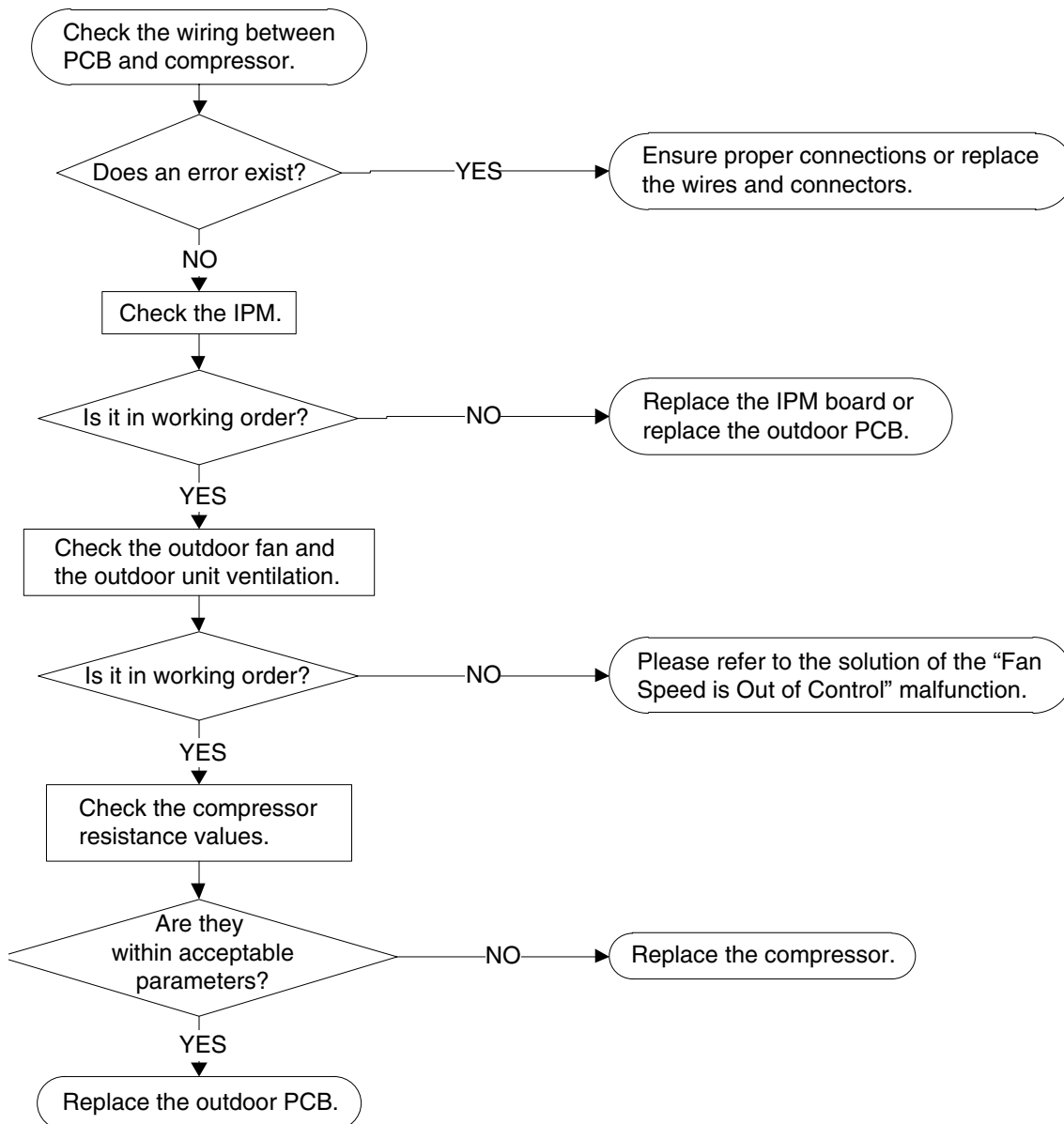

#### Note:

For certain models, outdoor PCB could not be removed separately. In this case, the outdoor electric control box should be replaced as a whole.

### 8.5.10 P1 / PC 01 (Over voltage or too low voltage protection diagnosis and solution)

**Description:** Abnormal increases or decreases in voltage are detected by checking the specified voltage detection circuit.

**Recommended parts to prepare:**

- Power supply wires
- IPM module board
- Outdoor PCB
- Reactor

**Troubleshooting and repair:**

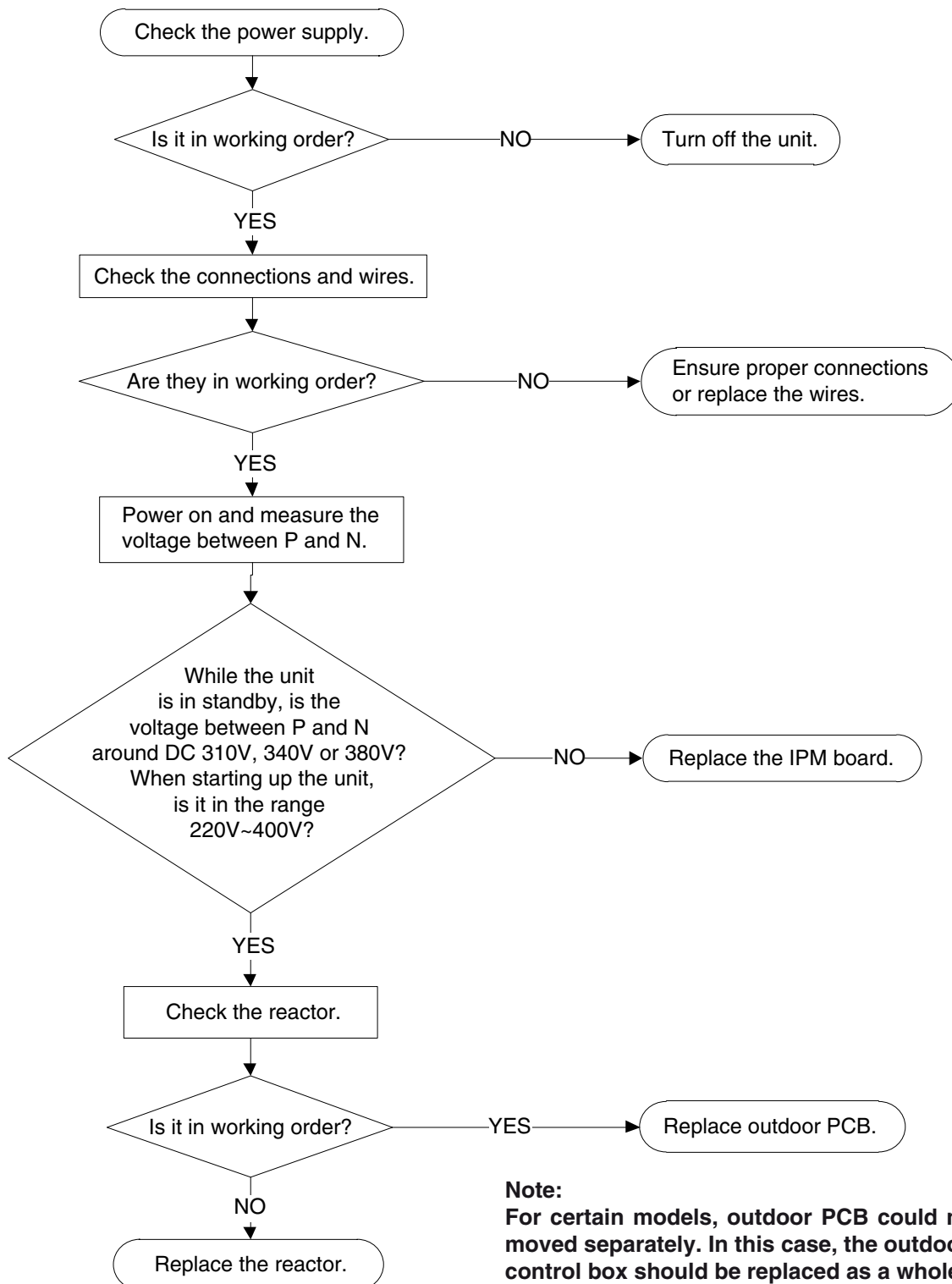

**Note:**  
For certain models, outdoor PCB could not be removed separately. In this case, the outdoor electric control box should be replaced as a whole.

### 8.5.11 P2 / PC 02

#### (High temperature protection of IPM module or High pressure protection diagnosis and solution)

**Description:** If the temperature of IPM module is higher than a certain value, the LED displays this failure code. For some models with high pressure switch, outdoor pressure switch cuts off the system because high pressure is higher than 4.4 MPa, the LED displays the failure code.

#### Recommended parts to prepare or to check:

- Connection wires
- Outdoor PCB
- IPM module board
- High pressure protector
- System blockages

#### Troubleshooting and repair:

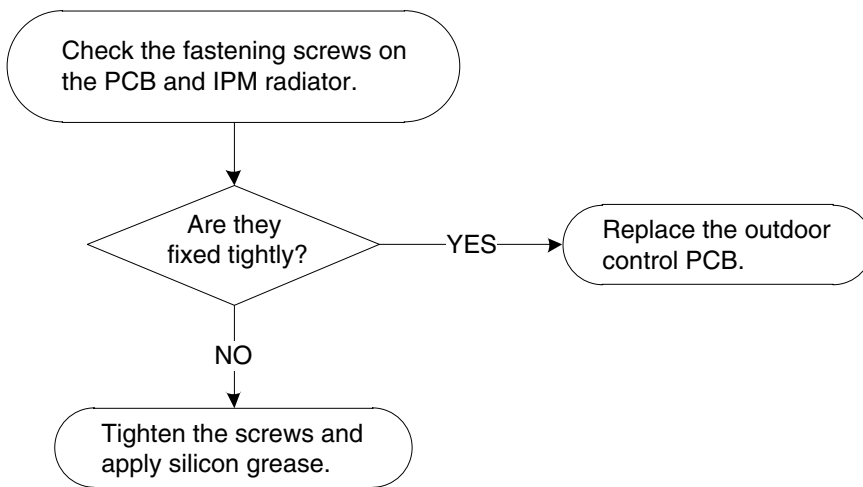

#### Note:

For certain models, outdoor PCB could not be removed separately. In this case, the outdoor electric control box should be replaced as a whole.

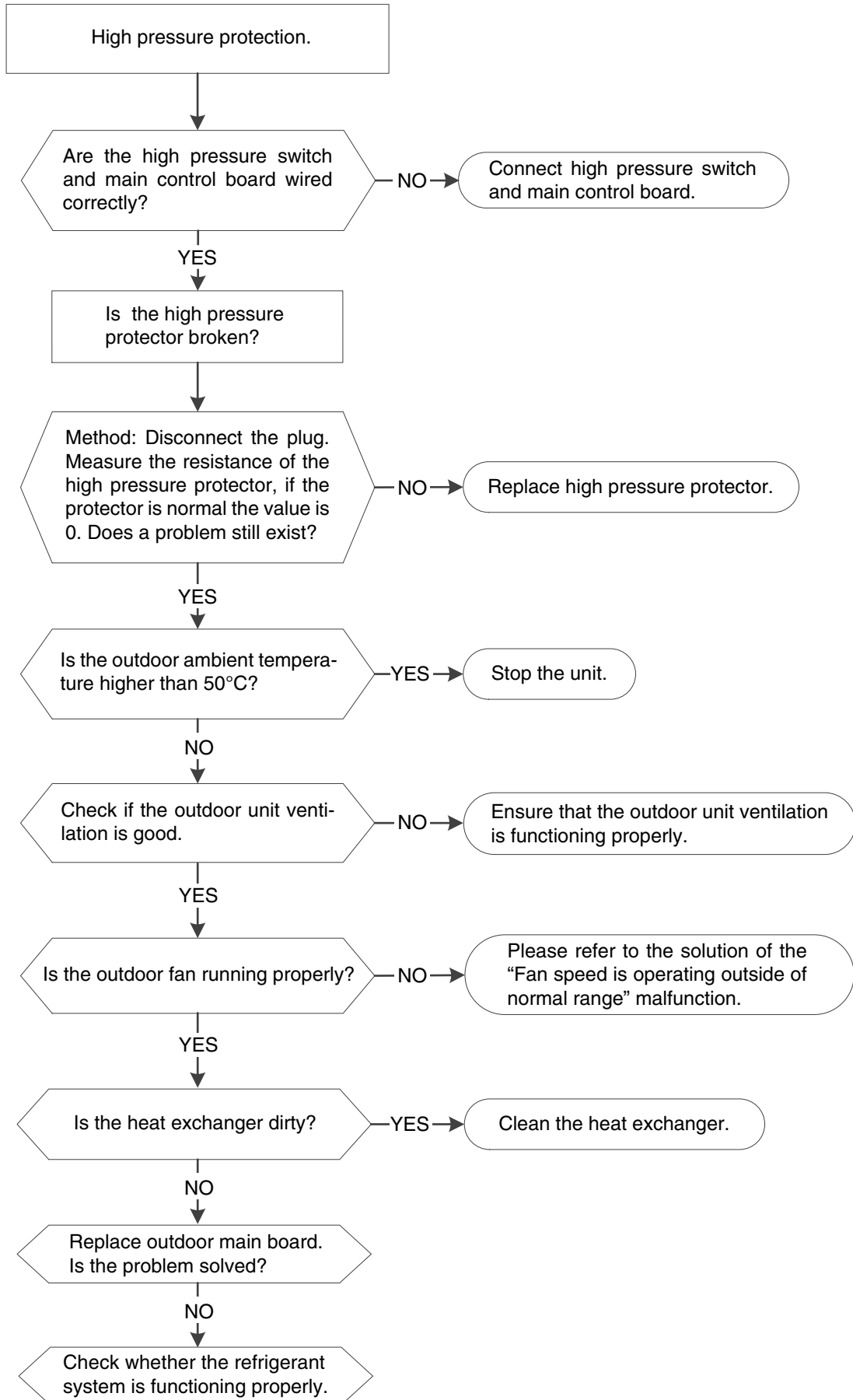

### 8.5.12 P4 / PC 04 (Inverter compressor drive error diagnosis and solution)

**Description:** An abnormal inverter compressor drive is detected by a special detection circuit, including communication signal detection, voltage detection, compressor rotation speed signal detection and so on.

#### Recommended parts to prepare or to check:

- Connection wires
- IPM module board
- Outdoor fan assembly
- Compressor
- Outdoor PCB

#### Troubleshooting and repair:

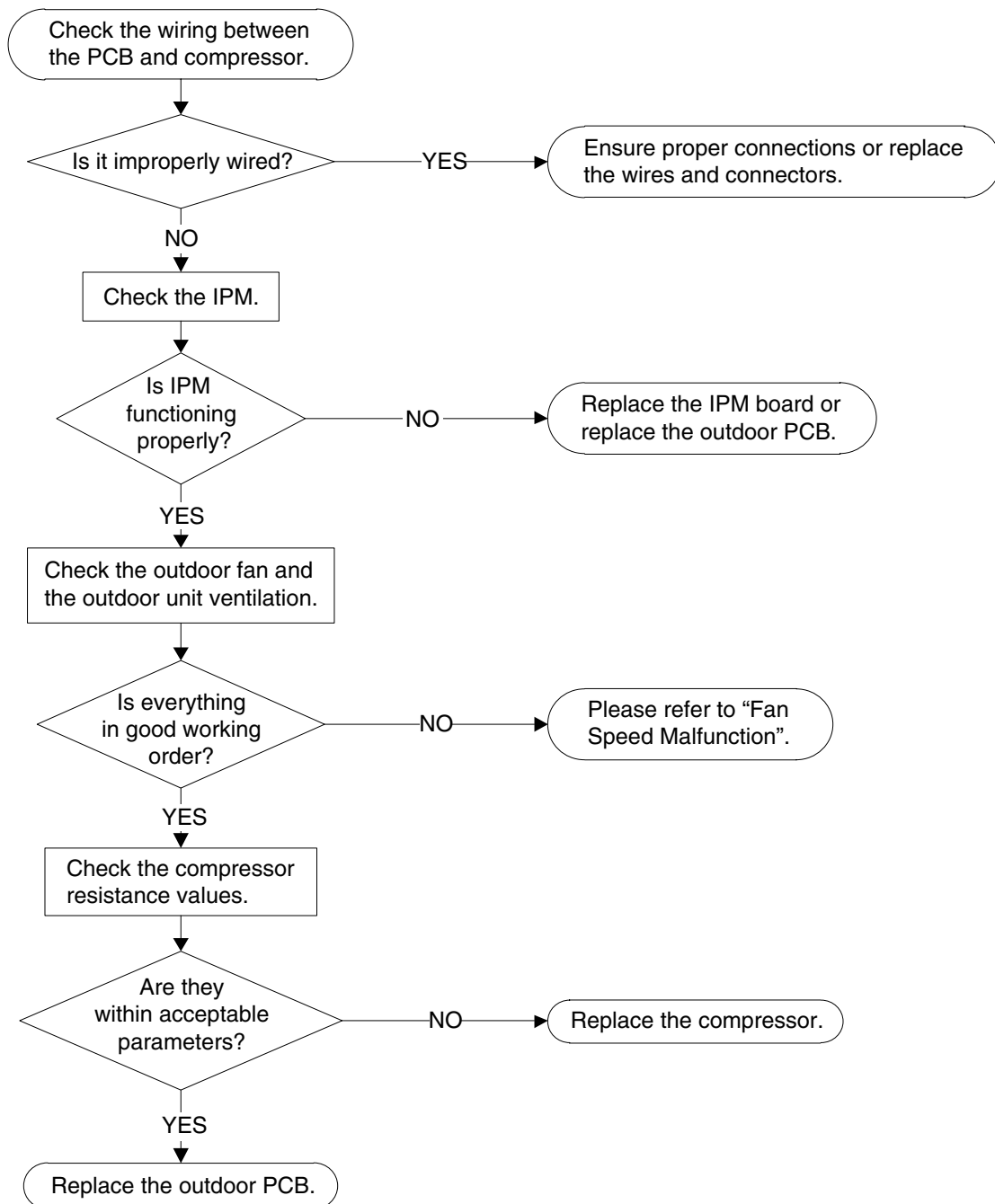

#### Note:

For certain models, outdoor PCB could not be removed separately. In this case, the outdoor electric control box should be replaced as a whole.

### 8.5.13 PC 03 (Low pressure protection)

**Description:** Outdoor pressure switch cuts off the system because low pressure is lower than 0.13 MPa, the LED displays the failure code.

**Recommended parts to prepare or to check:**

- Connection wires
- Outdoor PCB
- Low pressure protector
- Refrigerant

**Troubleshooting and repair:**

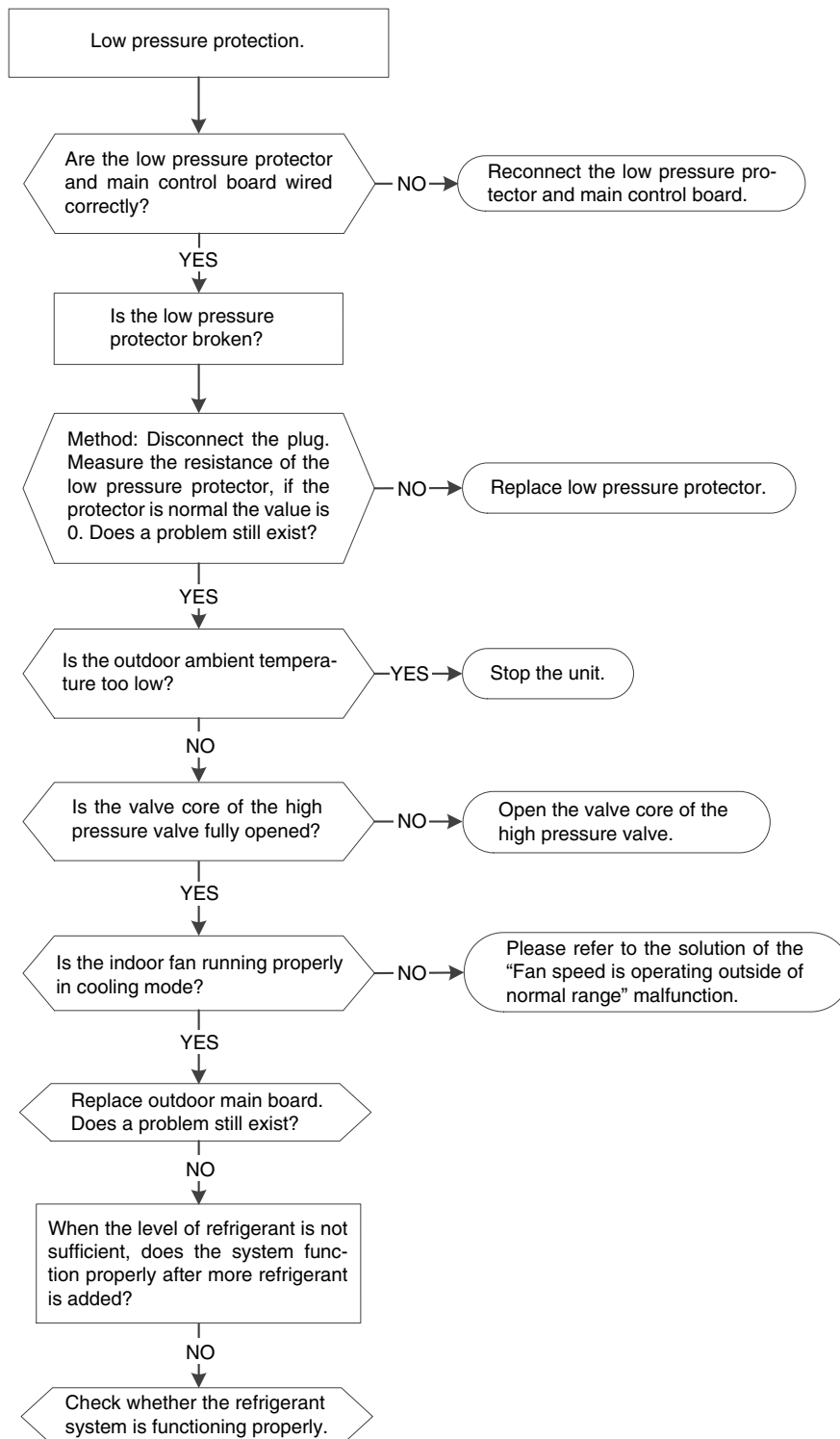

## 8.6 CHECK PROCEDURES

### 8.6.1 Temperature Sensor Check



**Warning:** Be sure to turn off all power supplies or disconnect all wires to avoid electric shock. Operate after compressor and coil have returned to normal temperature to avoid any injuries.

1. Disconnect the temperature sensor from PCB (refer to **Chapter 6** and **Chapter 7**).
2. Measure the resistance value of the sensor using a multi-meter.
3. Check corresponding temperature sensor resistance value table (refer to **Chapter 9**).

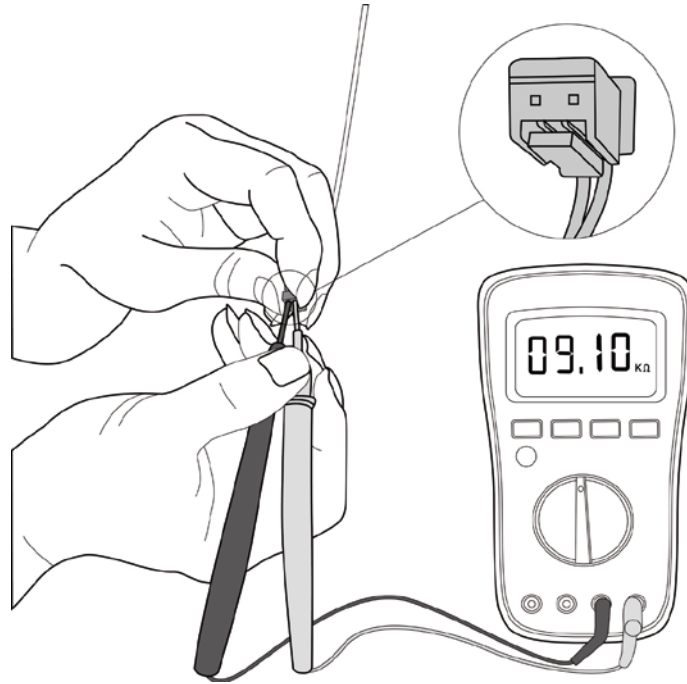

**Note:** The picture and the value are only for reference, actual condition and specific value may vary.

### 8.6.2 Compressor Check

1. Disconnect the compressor power cord from outdoor PCB (refer to **Chapter 7**).
2. Measure the resistance value of each winding using a multi-meter.
3. Check the resistance value of each winding, according to the following table.

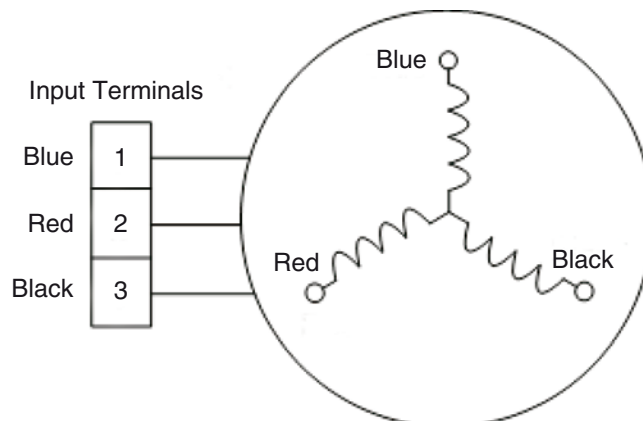



**Models HCNMX 353**

Position	Compressor Model / Resistance Value
Terminals: Blue - Red	KSK89D53UEZ / 2.35 $\Omega$
Terminals: Blue - Black	
Terminals: Red - Black	

**Model HCNI 533**

Position	Compressor Model / Resistance Value
Terminals: Blue - Red	KSN140D21UFZ / 1.28 $\Omega$
Terminals: Blue - Black	
Terminals: Red - Black	

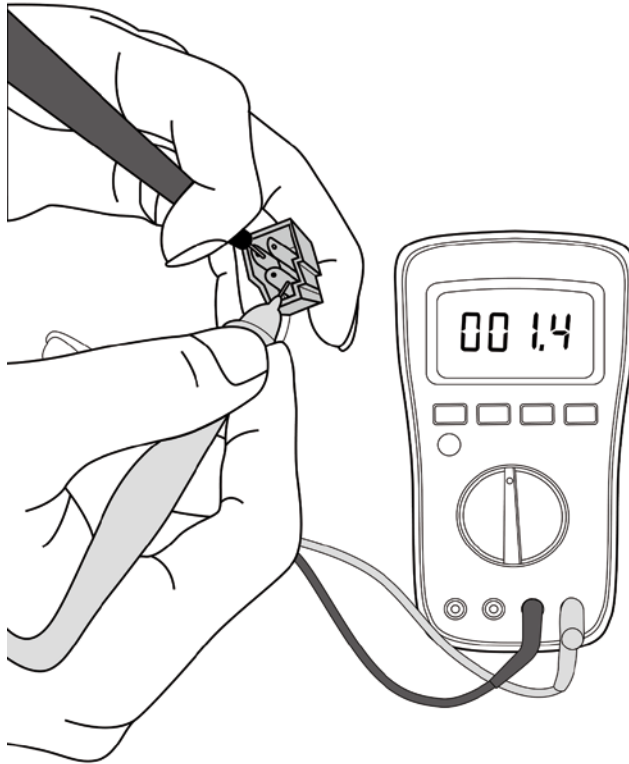

**Note:** The picture and the value are only for reference, actual condition and specific value may vary.

### 8.6.3 IPM Continuity Check



**Warning: Electricity remains in capacitors even when the power supply is off. Ensure the capacitors are fully discharged before troubleshooting.**

1. Turn off outdoor unit and disconnect power supply.
2. Discharge electrolytic capacitors and ensure all energy-storage unit has been discharged.
3. Disassemble outdoor PCB or disassemble IPM board.
4. Measure the resistance value between P and U (V, W, N); U (V, W) and N.

Digital Tester		Normal Resistance value	Digital Tester		Normal Resistance value
(+) Red	(-) Black		(+) Red	(-) Black	
P	N	$\infty$ (Several M $\Omega$ )	U	N	$\infty$ (Several M $\Omega$ )
	U		W		
	W		V		
	V		-		

## 8.6.4 Fan Motor Check

1. Turn off outdoor unit and disconnect power supply.
2. Disconnect outdoor fan motor power cord from outdoor PCB.
3. Measure the resistance value between each windings.

The normal resistance values of different fan motor models are as follows:

Fan Motor Model	YKFG-13-4-38L YKFG-13-4-38L-4	YKFG-15-4-28-1	YKFG-20-4-10L	YKFG-20-4-5-11
Brand	Welling	Welling	Welling	Welling
Black - Red Main	345Ω	75Ω	269Ω	388Ω
Blue - Black AUX	348Ω	150Ω	224Ω	360Ω

Fan Motor Model	YKFG-20-4-5-19	YKFG-25-4-6-14	YKFG-28-4-3-7 YKFG-28-4-3-14	YKFG-28-4-6-5
Brand	Welling	Welling	Welling	Welling
Black - Red Main	444Ω	287Ω	231Ω	183.6Ω
Blue - Black AUX	470Ω	409Ω	414Ω	206Ω

Fan Motor Model	YKFG-45-4-13	YKFG-45-4-22 YKFG-45-4-22-13	YKFG-60-4-2-6
Brand	Dongfang	Welling	Welling
Black - Red Main	125.2Ω	168Ω	96Ω
Blue - Black AUX	83.8Ω	141Ω	96Ω

## 9. APPENDIX

### 9.1 TEMPERATURE SENSOR RESISTANCE VALUE TABLES

#### i) Temperature Sensors T1, T2, T3 and T4 (°C – kΩ)

°C	°F	kΩ	°C	°F	kΩ	°C	°F	kΩ	°C	°F	kΩ
-20	-4	115.266	20	68	12.6431	60	140	2.35774	100	212	0.62973
-19	-2	108.146	21	70	12.0561	61	142	2.27249	101	214	0.61148
-18	0	101.517	22	72	11.5	62	144	2.19073	102	216	0.59386
-17	1	96.3423	23	73	10.9731	63	145	2.11241	103	217	0.57683
-16	3	89.5865	24	75	10.4736	64	147	2.03732	104	219	0.56038
-15	5	84.219	25	77	10	65	149	1.96532	105	221	0.54448
-14	7	79.311	26	79	9.55074	66	151	1.89627	106	223	0.52912
-13	9	74.536	27	81	9.12445	67	153	1.83003	107	225	0.51426
-12	10	70.1698	28	82	8.71983	68	154	1.76647	108	226	0.49989
-11	12	66.0898	29	84	8.33566	69	156	1.70547	109	228	0.486
-10	14	62.2756	30	86	7.97078	70	158	1.64691	110	230	0.47256
-9	16	58.7079	31	88	7.62411	71	160	1.59068	111	232	0.45957
-8	18	56.3694	32	90	7.29464	72	162	1.53668	112	234	0.44699
-7	19	52.2438	33	91	6.98142	73	163	1.48481	113	235	0.43482
-6	21	49.3161	34	93	6.68355	74	165	1.43498	114	237	0.42304
-5	23	46.5725	35	95	6.40021	75	167	1.38703	115	239	0.41164
-4	25	44	36	97	6.13059	76	169	1.34105	116	241	0.4006
-3	27	41.5878	37	99	5.87359	77	171	1.29078	117	243	0.38991
-2	28	39.8239	38	100	5.62961	78	172	1.25423	118	244	0.37956
-1	30	37.1988	39	102	5.39689	79	174	1.2133	119	246	0.36954
0	32	35.2024	40	104	5.17519	80	176	1.17393	120	248	0.35982
1	34	33.3269	41	106	4.96392	81	178	1.13604	121	250	0.35042
2	36	31.5635	42	108	4.76253	82	180	1.09958	122	252	0.3413
3	37	29.9058	43	109	4.5705	83	181	1.06448	123	253	0.33246
4	39	28.3459	44	111	4.38736	84	183	1.03069	124	255	0.3239
5	41	26.8778	45	113	4.21263	85	185	0.99815	125	257	0.31559
6	43	25.4954	46	115	4.04589	86	187	0.96681	126	259	0.30754
7	45	24.1932	47	117	3.88673	87	189	0.93662	127	261	0.29974
8	46	22.5662	48	118	3.73476	88	190	0.90753	128	262	0.29216
9	48	21.8094	49	120	3.58962	89	192	0.8795	129	264	0.28482
10	50	20.7184	50	122	3.45097	90	194	0.85248	130	266	0.2777
11	52	19.6891	51	124	3.31847	91	196	0.82643	131	268	0.27078
12	54	18.7177	52	126	3.19183	92	198	0.80132	132	270	0.26408
13	55	17.8005	53	127	3.07075	93	199	0.77709	133	271	0.25757
14	57	16.9341	54	129	2.95896	94	201	0.75373	134	273	0.25125
15	59	16.1156	55	131	2.84421	95	203	0.73119	135	275	0.24512
16	61	15.3418	56	133	2.73823	96	205	0.70944	136	277	0.23916
17	63	14.6181	57	135	2.63682	97	207	0.68844	137	279	0.23338
18	64	13.918	58	136	2.53973	98	208	0.66818	138	280	0.22776
19	66	13.2631	59	138	2.44677	99	210	0.64862	139	282	0.22231

## ii) Temperature Sensor TP (for some units) (°C – kΩ)

°C	°F	kΩ	°C	°F	kΩ	°C	°F	kΩ	°C	°F	kΩ
-20	-4	542.7	20	68	68.66	60	140	13.59	100	212	3.702
-19	-2	511.9	21	70	65.62	61	142	13.11	101	214	3.595
-18	0	483	22	72	62.73	62	144	12.65	102	216	3.492
-17	1	455.9	23	73	59.98	63	145	12.21	103	217	3.392
-16	3	430.5	24	75	57.37	64	147	11.79	104	219	3.296
-15	5	406.7	25	77	54.89	65	149	11.38	105	221	3.203
-14	7	384.3	26	79	52.53	66	151	10.99	106	223	3.113
-13	9	363.3	27	81	50.28	67	153	10.61	107	225	3.025
-12	10	343.6	28	82	48.14	68	154	10.25	108	226	2.941
-11	12	325.1	29	84	46.11	69	156	9.902	109	228	2.86
-10	14	307.7	30	86	44.17	70	158	9.569	110	230	2.781
-9	16	291.3	31	88	42.33	71	160	9.248	111	232	2.704
-8	18	275.9	32	90	40.57	72	162	8.94	112	234	2.63
-7	19	261.4	33	91	38.89	73	163	8.643	113	235	2.559
-6	21	247.8	34	93	37.3	74	165	8.358	114	237	2.489
-5	23	234.9	35	95	35.78	75	167	8.084	115	239	2.422
-4	25	222.8	36	97	34.32	76	169	7.82	116	241	2.357
-3	27	211.4	37	99	32.94	77	171	7.566	117	243	2.294
-2	28	200.7	38	100	31.62	78	172	7.321	118	244	2.233
-1	30	190.5	39	102	30.36	79	174	7.086	119	246	2.174
0	32	180.9	40	104	29.15	80	176	6.859	120	248	2.117
1	34	171.9	41	106	28	81	178	6.641	121	250	2.061
2	36	163.3	42	108	26.9	82	180	6.43	122	252	2.007
3	37	155.2	43	109	25.86	83	181	6.228	123	253	1.955
4	39	147.6	44	111	24.85	84	183	6.033	124	255	1.905
5	41	140.4	45	113	23.89	85	185	5.844	125	257	1.856
6	43	133.5	46	115	22.89	86	187	5.663	126	259	1.808
7	45	127.1	47	117	22.1	87	189	5.488	127	261	1.762
8	46	121	48	118	21.26	88	190	5.32	128	262	1.717
9	48	115.2	49	120	20.46	89	192	5.157	129	264	1.674
10	50	109.8	50	122	19.69	90	194	5	130	266	1.632
11	52	104.6	51	124	18.96	91	196	4.849			
12	54	99.69	52	126	18.26	92	198	4.703			
13	55	95.05	53	127	17.58	93	199	4.562			
14	57	90.66	54	129	16.94	94	201	4.426			
15	59	86.49	55	131	16.32	95	203	4.294			
16	61	82.54	56	133	15.73	96	205	4.167			
17	63	78.79	57	135	15.16	97	207	4.045			
18	64	75.24	58	136	14.62	98	208	3.927			
19	66	71.86	59	138	14.09	99	210	3.812			

## 9.2 PRESSURE ON SERVICE PORT (R32 REFRIGERANT)

Cooling chart:

Temp. (°C)	Outdoor (DB)		-17	-15	-9.44	7.22	23.89	29.44	35	40.56	46.11	48.89
	Indoor (DB/WB)											
Bar	21.11/15		6.5	6.6	7.4	8.2	8.4	8.0	8.3	8.8	10.3	10.8
Bar	23.89/17.22		6.8	6.9	8.1	8.8	8.8	8.5	8.9	9.3	10.9	11.4
Bar	26.67/19.44		7.2	7.3	8.7	9.7	9.5	9.1	9.3	9.8	11.4	12.1
Bar	32.22/22.78		7.9	8.0	9.8	10.7	10.5	9.7	10.2	10.8	12.6	13.3

Temp. (°C)	Outdoor (DB)		-17	-15	-9.44	7.22	23.89	29.44	35	40.56	46.11	48.89
	Indoor (DB/WB)											
Psi	21.11/15		95	96	108	118	121	115	119	128	150	157
Psi	23.89/17.22		99	101	117	128	126	122	129	135	158	165
Psi	26.67/19.44		105	106	125	141	138	132	135	143	165	176
Psi	32.22/22.78		114	115	142	155	152	141	148	157	184	193

Temp. (°C)	Outdoor (DB)		-17	-15	-9.44	7.22	23.89	29.44	35	40.56	46.11	48.89
	Indoor (DB/WB)											
MPa	21.11/15		0.65	0.66	0.74	0.82	0.84	0.80	0.83	0.88	1.03	1.08
MPa	23.89/17.22		0.68	0.69	0.81	0.88	0.88	0.85	0.89	0.93	1.09	1.14
MPa	26.67/19.44		0.72	0.73	0.87	0.97	0.95	0.91	0.93	0.98	1.14	1.21
MPa	32.22/22.78		0.79	0.80	0.98	1.07	1.05	0.97	1.02	1.08	1.26	1.33

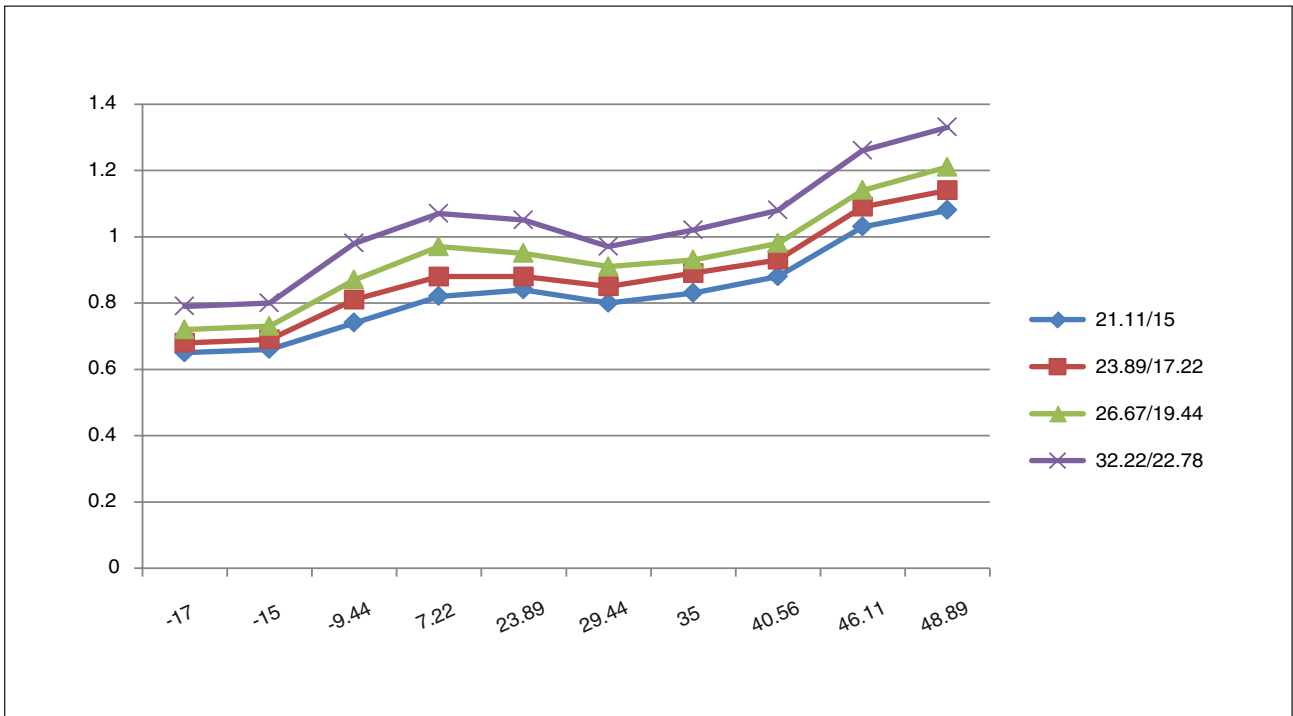

Heating chart:

Temp. (°C)	Outdoor (DB/WB)		13.89/11.67	8.33/6.11	2.78/0.56	-2.78/-5	-8.33/-10.56	-17/-19	-27/-28
	Indoor (DB)								
Bar	12.78		30.9	29.1	25.8	23.3	21.2	18.9	16.8
Bar	18.33		33.2	30.6	27.1	25.9	23.8	20.9	19.4
Bar	23.89		34.5	32.1	28.4	26.8	25.4	21.9	20.4

Temp. (°C)	Outdoor (DB/WB)		13.89/11.67	8.33/6.11	2.78/0.56	-2.78/-5	-8.33/-10.56	-17/-19	-27/-28
	Indoor (DB)								
Psi	12.78		448	421	374	337	308	273	244
Psi	18.33		480	444	394	375	346	303	282
Psi	23.89		499	466	411	389	369	318	296

Temp. (°C)	Outdoor (DB/WB)		13.89/11.67	8.33/6.11	2.78/0.56	-2.78/-5	-8.33/-10.56	-17/-19	-27/-28
	Indoor (DB)								
MPa	12.78		3.09	2.91	2.58	2.33	2.12	1.89	1.68
MPa	18.33		3.32	3.06	2.71	2.59	2.38	2.09	1.94
MPa	23.89		3.45	3.21	2.84	2.68	2.54	2.19	2.04

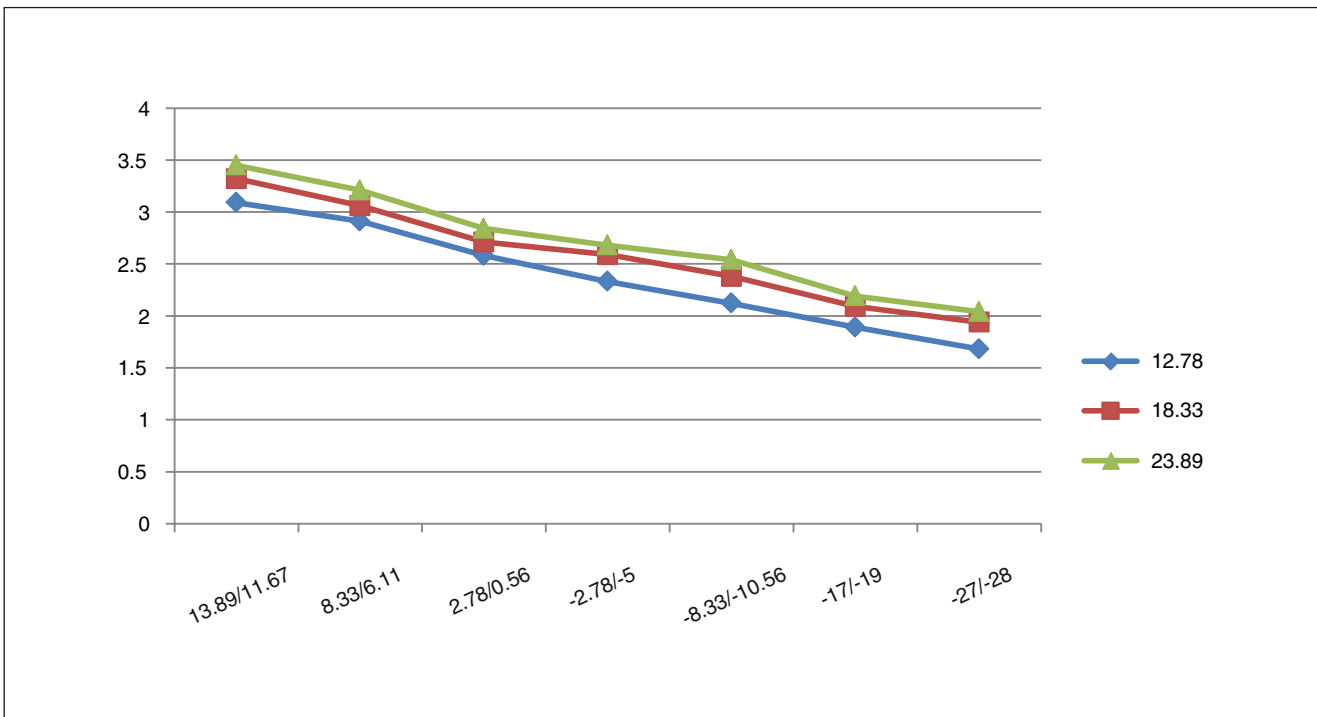

## System Pressure Table (R32)

Pressure			Temperature		Pressure			Temperature	
Kpa	Bar	Psi	°C	°F	Kpa	Bar	Psi	°C	°F
100	1	14.5	-51.909	-61.436	1850	18.5	268.25	28.425	83.165
150	1.5	21.75	-43.635	-46.543	1900	19	275.5	29.447	85.005
200	2	29	-37.323	-35.181	1950	19.5	282.75	30.448	86.806
250	2.5	36.25	-32.15	-25.87	2000	20	290	31.431	88.576
300	3	43.5	-27.731	-17.916	2050	20.5	297.25	32.395	90.311
350	3.5	50.75	-23.85	-10.93	2100	21	304.5	33.341	92.014
400	4	58	-20.378	-4.680	2150	21.5	311.75	34.271	93.688
450	4.5	65.25	-17.225	0.995	2200	22	319	35.184	95.331
500	5	72.5	-14.331	6.204	2250	22.5	326.25	36.082	96.948
550	5.5	79.75	-11.65	11.03	2300	23	333.5	36.965	98.537
600	6	87	-9.150	15.529	2350	23.5	340.75	37.834	100.101
650	6.5	94.25	-6.805	19.752	2400	24	348	38.688	101.638
700	7	101.5	-4.593	23.734	2450	24.5	355.25	39.529	103.152
750	7.5	108.75	-2.498	27.505	2500	25	362.5	40.358	104.644
800	8	116	-0.506	31.089	2550	25.5	369.75	41.173	106.111
850	8.5	123.25	1.393	34.507	2600	26	377	41.977	107.559
900	9	130.5	3.209	37.777	2650	26.5	384.25	42.769	108.984
950	9.5	137.75	4.951	40.911	2700	27	391.5	43.55	110.39
1000	10	145	6.624	43.923	2750	27.5	398.75	44.32	111.776
1050	10.5	152.25	8.235	46.823	2800	28	406	45.079	113.142
1100	11	159.5	9.790	49.621	2850	28.5	413.25	45.828	114.490
1150	11.5	166.75	11.291	52.324	2900	29	420.5	46.567	115.821
1200	12	174	12.745	54.941	2950	29.5	427.75	47.296	117.133
1250	12.5	181.25	14.153	57.475	3000	30	435	48.015	118.427
1300	13	188.5	15.52	59.936	3050	30.5	442.25	48.726	119.707
1350	13.5	195.75	16.847	62.325	3100	31	449.5	49.428	120.970
1400	14	203	18.138	64.648	3150	31.5	456.75	50.121	122.218
1450	14.5	210.25	19.395	66.911	3200	32	464	50.806	123.451
1500	15	217.5	20.619	69.114	3250	32.5	471.25	51.482	124.668
1550	15.5	224.75	21.813	71.263	3300	33	478.5	52.15	125.87
1600	16	232	22.978	73.360	3350	33.5	485.75	52.811	127.060
1650	16.5	239.25	24.116	75.409	3400	34	493	53.464	128.235
1700	17	246.5	25.229	77.412	3450	34.5	500.25	54.11	129.398
1750	17.5	253.75	26.317	79.371	3500	35	507.5	54.748	130.546
1800	18	261	27.382	81.288					









**MARK BV**

BENEDEN VERLAAT 87-89  
VEENDAM (NEDERLAND)  
POSTBUS 13, 9640 AA VEENDAM  
TELEFOON +31(0)598 656600  
FAX +31 (0)598 624584  
info@mark.nl  
www.mark.nl

**MARK EIRE BV**

COOLEA, MACROOM  
CO. CORK  
P12 W660 (IRELAND)  
PHONE +353 (0)26 45334  
FAX +353 (0)26 45383  
sales@markeire.com  
www.markeire.com

**MARK BELGIUM b.v.b.a.**

ENERGIELAAN 12  
2950 KAPellen  
(BELGIË/BELGIQUE)  
TELEFOON +32 (0)3 6669254  
info@markbelgium.be  
www.markbelgium.be

**MARK DEUTSCHLAND GmbH**

MAX-PLANCK-STRASSE 16  
46446 EMMERICH AM RHEIN  
(DEUTSCHLAND)  
TELEFON +49 (0)2822 97728-0  
TELEFAX +49 (0)2822 97728-10  
info@mark.de  
www.mark.de

**MARK POLSKA Sp. z o.o**

UL. JASNOGÓRSKA 27  
42-202 CZĘSTOCHOWA (POLSKA)  
PHONE +48 34 3683443  
FAX +48 34 3683553  
info@markpolska.pl  
www.markpolska.pl

**MARK SRL ROMANIA**

STR. BANEASA NO 8 (VIA STR. LIBERTATII)  
540199 TÂRGU-MURES, JUD MURES  
(ROMANIA)  
TEL/FAX +40 (0)265-266.332  
office@markromania.ro  
www.markromania.ro

